



Go Solar. Go Green.

— SOLAR PUMPING SYSTEMS —





C.R.I. PUMPS

Pumping trust. Worldwide.

T H E B E G I N N I N G

of C.R.I., way back in 1961, was a resolute attempt to produce a few irrigation equipments using the limited facilities of an in-house foundry. Eventually the founder's dream was coming true as the small production unit he started kept growing rapidly. Now, after more than five eventful decades, it is an enormous, widely reputed organization, which produces more than 1500 varieties of perfectly engineered pumps and motors and sells its products in numerous countries spread across 6 continents.

C . R . I . I S O N E A M O N G

the few pioneers in the world to produce 100% stainless steel submersible pumps. Having achieved a record production capacity of over 1.5 million pumps per annum, today C.R.I. is rubbing its shoulders with the best brands in the world, with advanced technology and safety standards as its hallmarks.

T H E I N F R A S T R U C T U R E

of C.R.I. is pretty comprehensive with state-of-the-art machineries and high potential in-house R&D recognised by the ministry of science and technology, Govt. of India - all within its own covered area of 200,000 square metres. The production environment is accredited with ISO 9001 & 14001 certifications and the products are CE, UR/UL, TSE & ISI certified. The R&D team always stays in tune with the changing scenario and seldom fails in coming up with outstanding solutions every time.

N E E D L E S S T O S A Y ,

behind this legendary growth lies the untiring, innovative, enthusiastic and dedicated team work. and, of course, a flawlessly maintained value system too. The name C.R.I. itself encapsulates the company's ethos: " Commitment, Reliability, Innovation".





C.R.I. PUMPS

Pumping trust. Worldwide.

Vision, Mission and values

To be the industry leader providing best - in - class fluid management solutions to individual and institutional customers and societies in our chosen markets.

We will achieve this through our dedicated efforts to enhance the welfare of all our stakeholders and by living by our values of commitment, reliability and Innovation.

C O N T E N T S

Page No.

	Page No.
SOLAR PUMPS	
General Information	05
DC SOLAR PUMPS	
Features, Applications & MIC	06
DC SOLAR SUBMERSIBLE PUMPS	
G3R SERIES	08
G3P SERIES	09
G4R SERIES	10
G4P SERIES	11
G4S SERIES	12
DC SOLAR SURFACE PUMPS	
Pool Pumps - GSP Series	14
Peripheral Pumps - GPE Series	15
SS Jet Pumps - GJS Series	16
Screw Pumps - GRP Series	17
Control Box & Installation Procedure	18
PV Modules Selection & Connection	19
Battery Mode Operation	20
AC SOLAR PUMP CONTROLLER	
General, Features, Applications & MIC	22
Specifications & Technical Details	23
Terminal Connection Diagram	24
SOLAR PHOTO VOLTAIC (PV) MODULES	
General & Features	25
Specifications	26
Solar Module Mounting Structures	29



SOLAR PUMPING SYSTEMS

GENERAL INFORMATION

C.R.I. Pumps with 5 decades of engineering expertise in the pump industry, understanding the importance of usage of Green energy and the current need across the world and has extended comprehensive range of solar pumping systems both in deepwell submersible and surface pump ranges. These product ranges ensure that even in areas where there is little or no power distribution, the need for water is met. It is also part of the Company's initiatives to promote green energy powered by the sun. C.R.I. Solar Pumping systems are designed & developed using the most advanced technologies suitable for various applications and giving more thrust on high performance and durability in both AC & DC versions.

DC Solar Pumps are available with both Screw & Centrifugal impellers suitable for different head and flow ranges. The DC Submersible Solar Pumps are powered by C.R.I. Oil filled permanent magnet, brushless DC motors and the Surface Pumps are coupled to specially designed dry type brushless DC motors. With regard to AC Pumps, C.R.I. Solar Pump Controller is used to convert DC Power generated by PV modules to 3Phase AC Power and drive these pumps.

SOLAR PV MODULE FUNCTIONALITY

PV Modules collect solar radiation from the sun and actively convert that energy to electricity. PV Modules are comprised of several individual solar cells and function similarly to large semiconductors and utilize a large-area p-n junction diode. When the solar cells are exposed to sunlight, the p-n junction diodes convert the energy from sunlight into usable electrical energy.

The energy generated from photons striking the surface of the PV Module allows electrons to be knocked out of their orbits and released, and electric fields in the solar cells pull these free electrons in a directional current (D.C.), from which metal contacts in the solar cell can generate electricity. The more solar cells in a PV Module and the higher the quality, the more total electrical output the PV Module can produce. The conversion of sunlight to usable electrical energy is otherwise known as the Photovoltaic Effect. The photovoltaic effect arises from the properties of the p-n junction diode, as such there are no moving parts in a PV Module.

PV MODULE OUTPUT

Factors that affect the output of PV Modules are weather conditions, shade caused by obstructions to direct sunlight, and the angle and position at which the PV Module is installed.

PV Modules delivers the best output when placed in direct sunlight, away from obstructions that might cast shade, and in areas with high regional solar insolation ratings.

PV Module efficiency can be optimized by using dynamic mounts that follow the position of the sun in the sky and rotate the PV Module to get the maximum amount of direct exposure during the day as possible.

SOLAR ENERGY STORAGE SYSTEM

In our system the collecting device is lead acid battery which collect and stores DC energy Generated from PV Modules. This battery power storage option is available in DC solar pumps ranging upto 500W. The D.C. Power stored in the battery can be used to operate the pump directly. This process is usually integrated into solar photovoltaic system where energy collected and stored almost instantaneously.

DC Solar Pumps

C.R.I. Solar D.C. Pump & Motor are supplied with necessary accessories like control box, level sensor probes, spare impeller, power cable to connect control box & panel & cables splicing kit as a complete set in a single carton packing.

Features : • Eco friendly • More Longevity & Hygiene • Uses only solar energy • Easy to dismantle & Repair • Rigid construction • Highly durable • Can handle upthrust load • Dry run protection • NEMA Mounting Standard (4") • Water level sensors for storage tank • Extremely hardwearing water lubricated bearings • Powered by brushless DC Motor for long life.

Applications : • Residential • Irrigation • Live stock farms • Small farms • Public water supply • De-watering • Industries • Golf course.

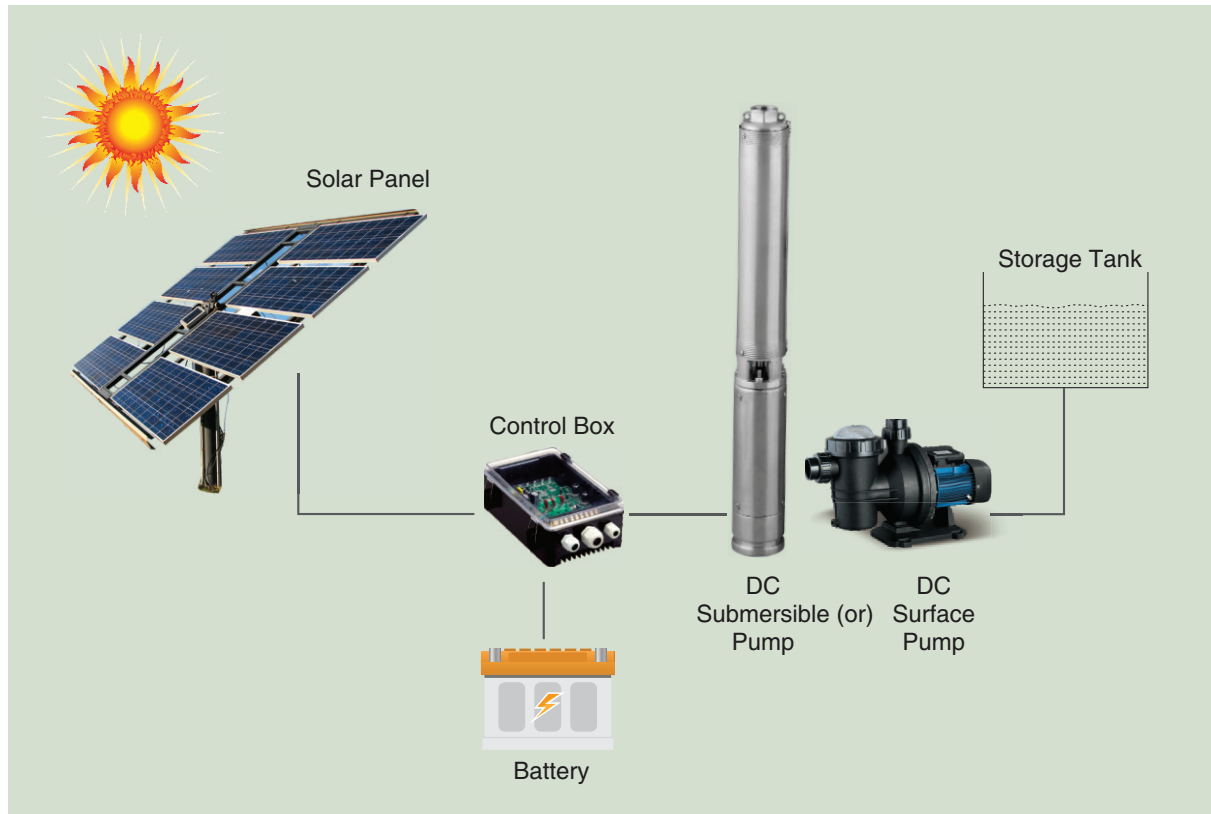

Model Identification Code

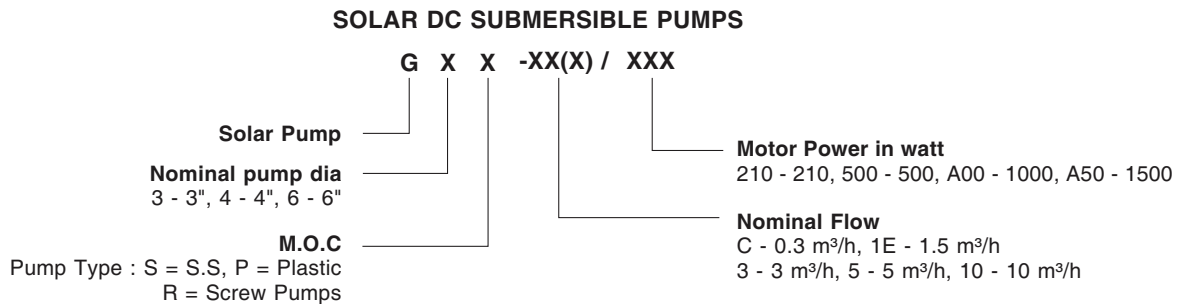

In view of continuous developments, the information / descriptions / specifications / illustrations are subject to change without notice.

SOLAR DC SURFACE PUMPS

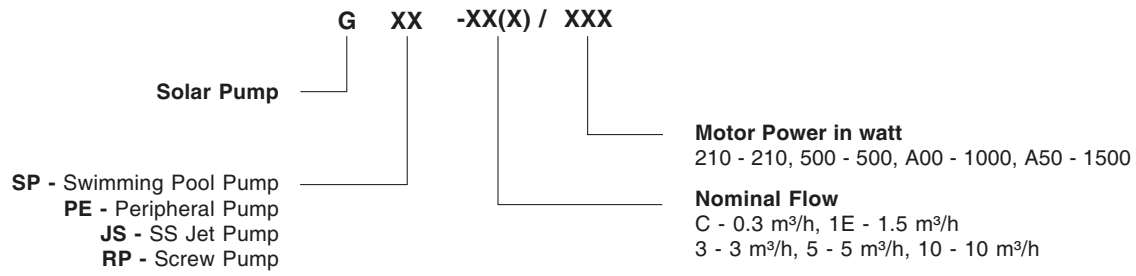

DC Solar Submersible Pumps



- 3" Screw type Deepwell Submersible Pumps
- 3" Centrifugal Deepwell Submersible Pumps - Plastic Impeller
- 4" Screw type Deepwell Submersible Pumps
- 4" Centrifugal Deepwell Submersible Pumps - Plastic Impeller
- 4" Centrifugal Deepwell Submersible Pumps - SS Impeller

G3R Series

SPECIFICATIONS

Nominal Dia.	3"
Power range	80 - 500 W
Voltage	12 - 48 V, D.C.
Max. Head	95 m
Max. Discharge	1.2 m ³ /h
Max. Immersion depth	30 m
Motor type	Oil filled DC motor
Impeller	Screw type
Outlet size	¾"

MATERIALS OF CONSTRUCTION

Outlet	Stainless steel
Pump outer shell	Stainless steel
Motor outer shell	Stainless steel
Impeller	Stainless steel (Screw type)
Bearing	Ball bearing

PERFORMANCE CURVES

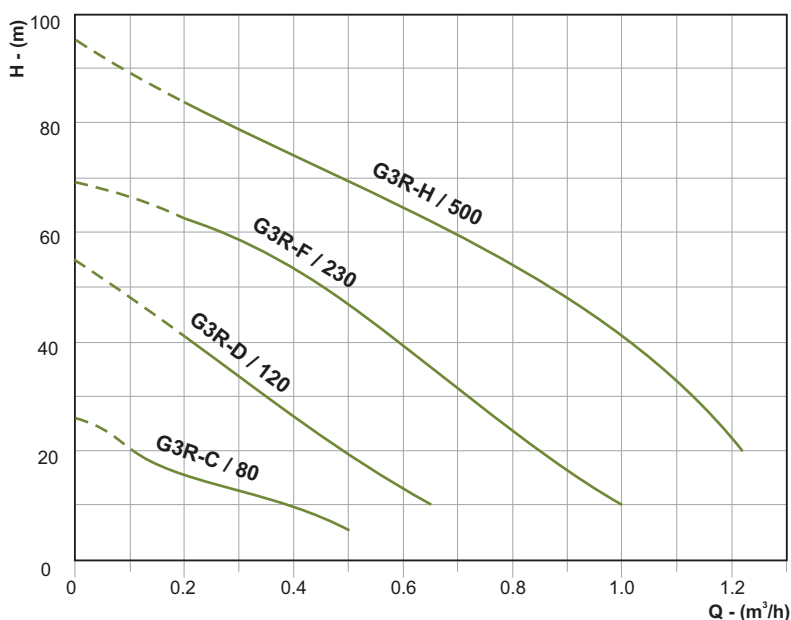

* Provide Non return valve (NRV) near the pump outlet to avoid water hammering / back flow of water.

PUMPSET CONSIST OF :

- Pump
- Motor
- Control box
- Level sensor probes
- Spare Screw impeller
- Power cable to connect control box & PV Module
- Cable splicing kit

PERFORMANCE TABLE

Model	Voltage (V)	Power (W)	Reqd. PV Input Power (W)	Max. Head (m)	Head Range (m)	Flow Range (LPD)*
G3R-C / 80	12	80	105	27	21 - 5	400 - 2000
G3R-D / 120	24	120	160	54	45 - 10	800 - 2600
G3R-F / 230	36	230	300	69	62 - 10	800 - 4000
G3R-H / 500	48	500	650	95	85 - 22	800 - 4800

The above performance curves are plotted under test condition with maximum DC input power.

* Flow range in LPD is calculated based on 4 hours bright sunny day.

In view of continuous developments, the information / descriptions / specifications / illustrations are subject to change without notice.

G3P Series

SPECIFICATIONS

Nominal Dia.	3"
Power range	210 - 500 W
Voltage	36 & 48 V, D.C.
Max. Head	70 m
Max. Discharge	3 m ³ /h
Max. Immersion depth	30 m
Motor type	Oil filled DC motor
Impeller	Multistage Centrifugal
Outlet size	1"

MATERIALS OF CONSTRUCTION

Outlet	Stainless steel
Pump outer shell	Stainless steel
Motor outer shell	Stainless steel
Impeller	Thermoplastic
Bearing	Ball bearing

PERFORMANCE CURVES

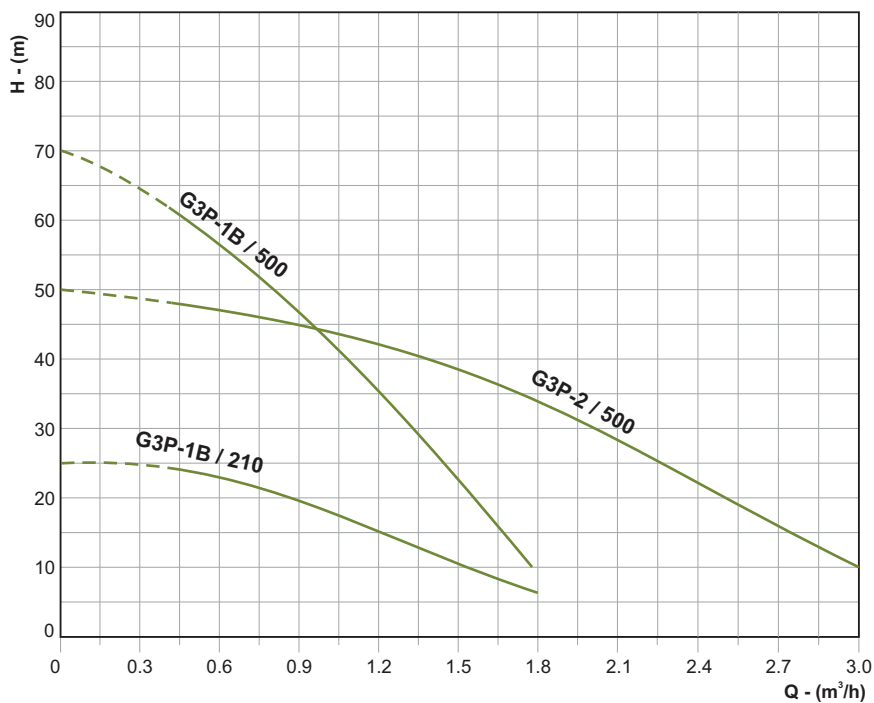

PUMPSET CONSIST OF :

- Pump
- Motor
- Control box
- Level sensor probes
- Spare Centrifugal impeller
- Power cable to connect control box & PV Modules
- Cable splicing kit.

PERFORMANCE TABLE

Model	Voltage (V)	Power (W)	Reqd. PV Input Power (W)	Max. Head (m)	Head Range (m)	Flow Range (LPD)*
G3P-1B / 210	36	210	270	25	23 - 6	1800 - 7200
G3P-1B / 500	48	500	650	70	62 - 10	1600 - 7200
G3P-2 / 500	48	500	650	50	47 - 10	1800 - 12000

The above performance curves are plotted under test condition with maximum DC input power.

* Flow range in LPD is calculated based on 4 hours bright sunny day.

In view of continuous developments, the information / descriptions / specifications / illustrations are subject to change without notice.

G4R Series

SPECIFICATIONS

Nominal Dia.	4"
Power range	500 - 1000 W
Voltage	48 & 110 V, D.C.
Max. Head	120 m
Max. Discharge	2.5 m ³ /h
Max. Immersion depth	30 m
Motor type	Oil filled DC motor
Impeller	Screw type
Outlet size	1"

MATERIALS OF CONSTRUCTION

Outlet	Stainless steel
Pump outer shell	Stainless steel
Motor outer shell	Stainless steel
Impeller	Stainless steel (Screw type)
Bearing	Ball bearing

PERFORMANCE CURVES

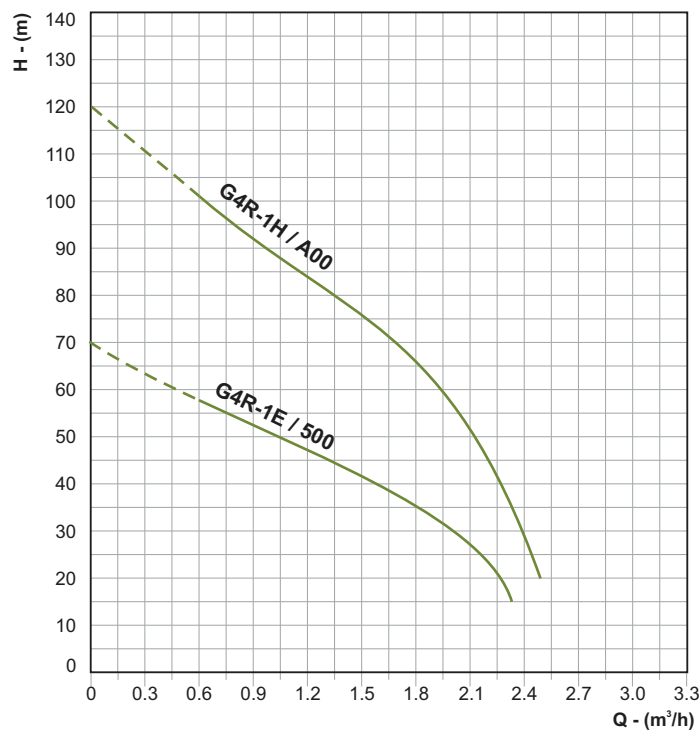

* Provide Non return valve (NRV) near the pump outlet to avoid water hammering / back flow of water.

PUMPSET CONSIST OF :

- Pump • Motor • Control box • Level sensor probes • Spare Screw impeller • Power cable to connect control box & PV Modules • Cable splicing kit.

PERFORMANCE TABLE

Model	Voltage (V)	Power (W)	Reqd. PV Input Power (W)	Max. Head (m)	Head Range (m)	Flow Range (LPD)*
G4R-1E / 500	48	500	650	70	58 - 15	2400 - 9000
G4R-1H / A00	110	1000	1400	120	100 - 20	2400 - 10000

The above performance curves are plotted under test condition with maximum DC input power.

* Flow range in LPD is calculated based on 4 hours bright sunny day.

In view of continuous developments, the information / descriptions / specifications / illustrations are subject to change without notice.

G4P Series

SPECIFICATIONS

Nominal Dia.	4"
Power range	500 - 1000 W
Voltage	48 & 110 V, D.C.
Max. Head	89 m
Max. Discharge	7 m ³ /h
Max. Immersion depth	30 m
Motor type	Oil filled DC motor
Impeller	Multistage centrifugal
Outlet size	1¼" & 2"

MATERIALS OF CONSTRUCTION

Outlet	Stainless steel
Pump outer shell	Stainless steel
Motor outer shell	Stainless steel
Impeller	Thermoplastic
Bearing	Ball bearing

PERFORMANCE CURVES

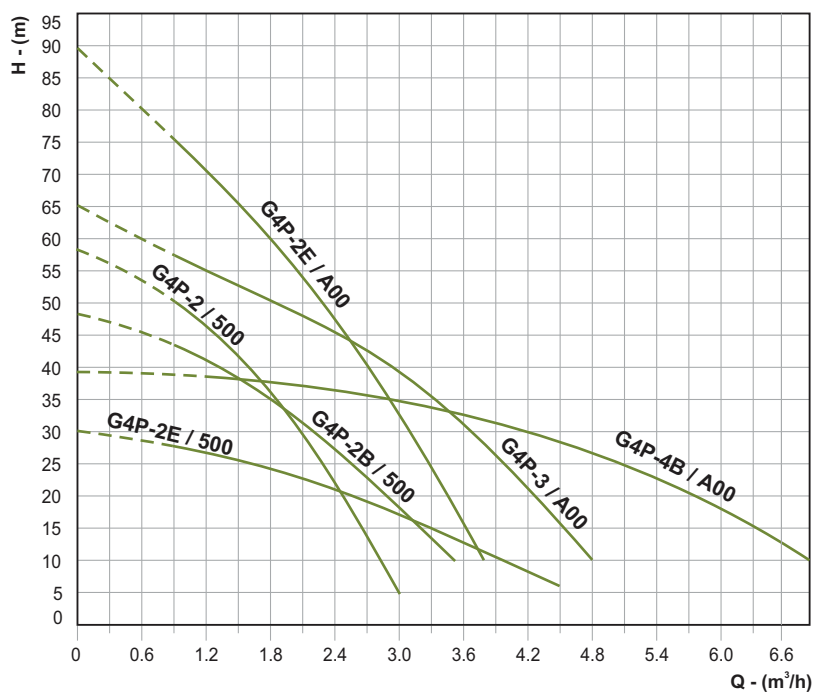

PUMPSET CONSIST OF :

- Pump
- Motor
- Control box
- Level sensor probes
- Spare Centrifugal impeller
- Power cable to connect control box & PV Modules
- Cable splicing kit

PERFORMANCE TABLE

Model	Voltage (V)	Power (W)	Reqd. PV Input Power (W)	Max. Head (m)	Head Range (m)	Flow Range (LPD)*
G4P-2 / 500	48	500	650	57	50 - 5	3600 - 12000
G4P-2B / 500	48	500	650	48	44 - 10	3600 - 14000
G4P-2E / 500	48	500	650	30	27 - 6	3600 - 18000
G4P-2E / A00	110	1000	1400	89	75 - 10	3600 - 15000
G4P-3 / A00	110	1000	1400	65	57 - 10	3600 - 19000
G4P-4B / A00**	110	1000	1400	39	37 - 10	5000 - 27600

The above performance curves are plotted under test condition with maximum DC input power.

* Flow range in LPD is calculated based on 4 hours bright sunny day.

** 2" Outlet

In view of continuous developments, the information / descriptions / specifications / illustrations are subject to change without notice.

G4S Series

SPECIFICATIONS

Nominal Dia.	4"
Power range	300 - 1000 W
Voltage	36 & 110 V, D.C.
Max. Head	110 m
Max. Discharge	6 m ³ /h
Max. Immersion depth	30 m
Motor type	Oil filled DC motor
Impeller	Multistage centrifugal
Outlet size	1¼" & 1½"

MATERIALS OF CONSTRUCTION

Outlet	Stainless steel
Pump outer shell	Stainless steel
Motor outer shell	Stainless steel
Impeller	Stainless steel
Bearing	Ball bearing

PERFORMANCE CURVES

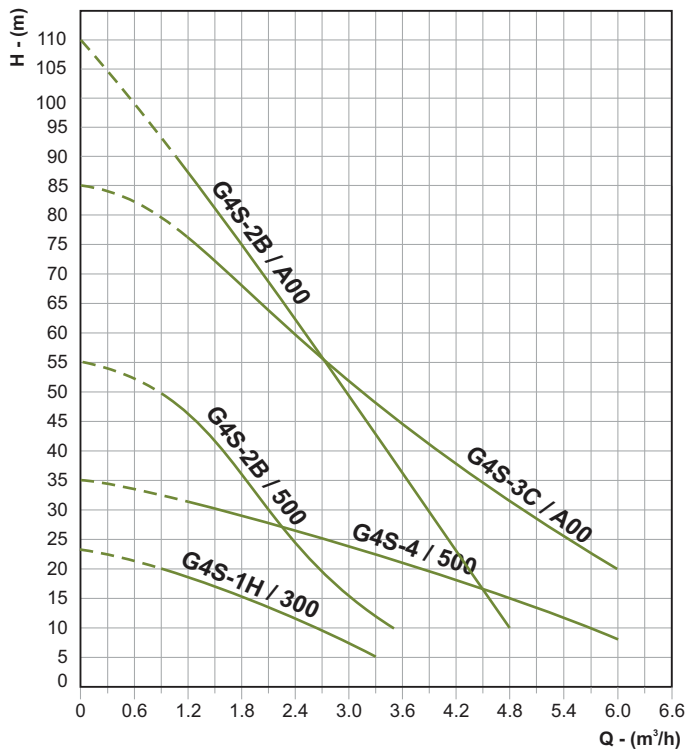

PUMPSET CONSIST OF :

- Pump ● Motor ● Control box ● Level sensor probes ● Spare Centrifugal impeller ● Power cable to connect control box & PV Modules ● Cable splicing kit

PERFORMANCE TABLE

Model	Voltage (V)	Power (W)	Reqd. PV Input Power (W)	Max. Head (m)	Head Range (m)	Flow Range (LPD)*
G4S-1H / 300	36	300	390	23	20 - 5	3600 - 13200
G4S-2B / 500	48	500	650	55	50 - 10	3000 - 14000
G4S-4 / 500	48	500	650	35	31 - 8	4800 - 24000
G4S-3C / A00**	110	1000	1400	85	76 - 20	4800 - 24000
G4S-2B / A00	110	1000	1400	110	90 - 10	4400 - 19200

** 1½" Outlet

The above performance curves are plotted under test condition with maximum DC input power.

* Flow range in LPD is calculated based on 4 hours bright sunny day.

In view of continuous developments, the information / descriptions / specifications / illustrations are subject to change without notice.

DC Control Box types and Connection Details

Model	GT-12-24	GT-36-48	GT-72-110*
Pump Voltage	12 / 24V DC	36 / 48V DC	72 / 110V DC
PV Input Voltage	> 34V DC	> 68V DC	> 136V DC
PV Max. (VOC)	50V DC	100V DC	200V DC
Battery Input Voltage	12 / 24V DC	36 / 48V DC	-
Low Voltage Cut-off	11 / 22V DC	33 / 46V DC	70 / 108V DC
Restart Voltage	11.7 / 23.4V DC	35 / 47V DC	71 / 109V DC
Rated Current	10 A	10 A	12.5 A
Max. Power	200 W	500 W	1200 W
Max. Ambient Temp.	50°C	50°C	50°C

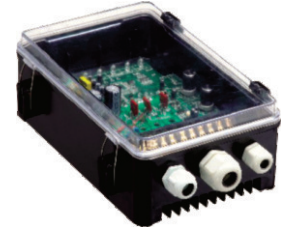

CABLE SIZE & SELECTION

The lead out cable size for submersible pumps upto 500W is 1.5 sq.mm. Use 2 sq.mm cable when installed for more than 20m length.

The lead out cable size for submersible pumps for 1000W is 2 sq.mm. Use 2.5 sq.mm cable when installed for more than 20m length.

INSTALLATION PROCEDURE

1. Open the packing and inspect the pump, control box, PV Modules and other accessories are in good condition.
2. Install the pumpset as like normal submersible / Surface pump and connect it to the control box, PV Modules, battery (if required) & water level sensors as given in the below diagram (fig. 1).
3. The ON / OFF switch must be in middle position (OFF position) while installation

Installation Procedure

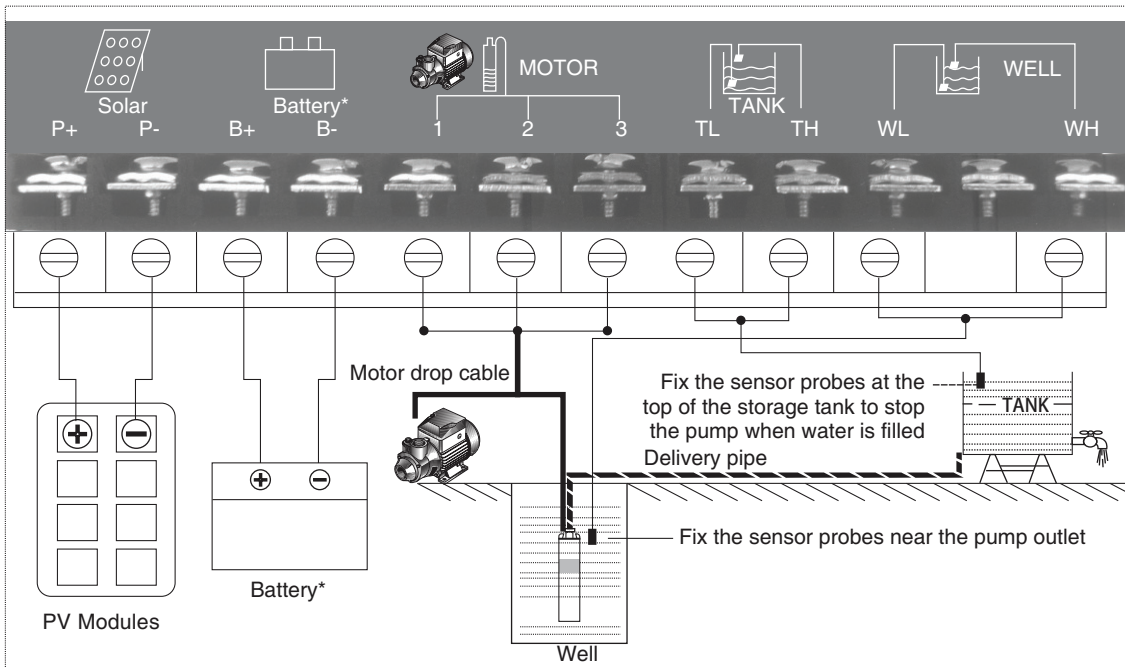

The above connection diagram is common for both submersible and surface pump installations.

FIG 1

Note :

1. Solar mode :
Switch position to "SOLAR"
2. Battery mode* :
Switch position to "BAT"

* Battery mode is not available for 1000 W pump models.

In view of continuous developments, the information / descriptions / specifications / illustrations are subject to change without notice.

PV Module Connections

Generally the PV Modules are available with specific Power (watts) and Voltage (volts) combinations. To get the reqd. D.C. output for operating the solar pump we need to either connect the panels in Series or Parallel or combination of Series & Parallel connections.

PV MODULES SELECTION

The power of PV Modules = power of pump x 1.3. The maximum Peak Voltage of the PV Modules must not exceeds the maximum Input Voltage of the system. In case of battery mode operation PV Modules power must be calculated as 1.5 times of pump power.

PV MODULES SELECTION CHART

Pump rating	PV Module Spec-Solar mode operation				PV Modules Connection Method	PV Module Spec-Battery mode operation			
	P _{max}	V _{mp}	V _{oc}	No. of Modules		P _{max}	V _{mp}	V _{oc}	No. of Modules
80W / 12V	105W	17-18	21-22	1	Direct	120W	17-18	21-22	1
120W / 24V	160W	34-36	42-44	1	Direct	180W	34-36	42-44	1
210W / 36V	90W	17-18	21-22	3	Series	110W	17-18	21-22	3
230W / 36V	100W	17-18	21-22	3	Series	115W	17-18	21-22	3
300W / 36V	130W	17-18	21-22	3	Series	150W	17-18	21-22	3
500W / 48V	85W	17-18	21-22	8	2x4 modules in series, 2 arrays in parallel	95W	17-18	21-22	8
600W / 48V	130W	24	29.5	6	2x3 modules in series, 2 arrays in parallel	150W	24	29.5	6
1000W / 110V	100W	17-18	21-22	14	2x7 modules in series, 2 arrays in parallel	NA	NA	NA	NA
1200W / 110V	100W	17-18	21-22	16	2x8 modules in series, 2 arrays in parallel	NA	NA	NA	NA
1500W / 110V	120W	17-18	21-22	16	2x8 modules in series, 2 arrays in parallel	NA	NA	NA	NA

SERIES CONNECTIONS

When the PV Modules are connected in series the output Power as well as Voltage of each Module will gets added.

PARALLEL CONNECTIONS

When the PV Modules are connected in parallel the output Power of each Module alone gets added.

Series connection diagram for 300W, 36V DC Solar Pump

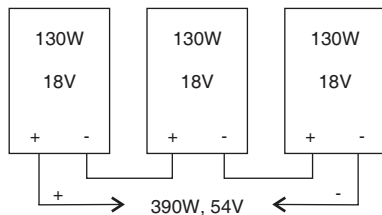

Parallel connection diagram for 150W, 36V DC Solar Pump

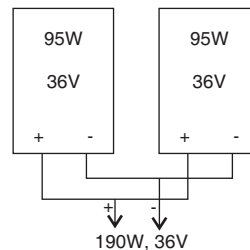

Combination of series & parallel connection diagram for 500W, 48V DC Solar Pump

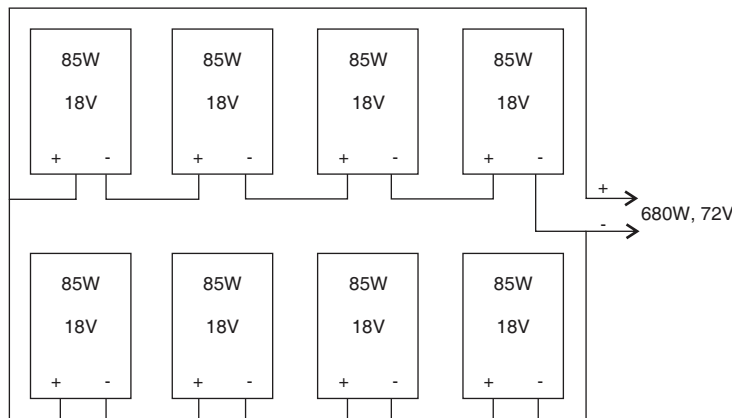

In view of continuous developments, the information / descriptions / specifications / illustrations are subject to change without notice.

Battery Mode Operation

The battery mode option is only available upto 500W DC Solar Pumps & higher power rating pumps do not have this facility. Connect the battery terminals with the control box terminal connections as shown in fig.1 (page 13).

Set the selector switch in the control box to battery mode so that the PV Modules array charges the battery and simultaneously supplies power to run the pump. While the system is operated with battery, the output power of solar modules should be 1.5 times of pump power, so that the battery can get charged and pump can also run simultaneously. When there is low / no sunlight the control box will take required power from batteries to run the pump.

Please refer below table for suitable battery capacities based on the pump voltage.

Pump Voltage	Battery Capacity	Qty	Connection
• 12V D.C. Solar Pump	150AH, 12V Battery	1 No	Direct
• 24V D.C. Solar Pump	150AH, 12V Battery	2 Nos.	Series connection
• 36V D.C. Solar Pump	150AH, 12V Battery	3 Nos.	Series Connection
• 48V D.C. Solar Pump	150AH, 12V Battery	4 Nos.	Series Connection

BATTERY SELECTION PROCEDURE

To calculate the battery capacity : $AH = \frac{T \times P}{V \times 0.6}$

To find the operating time of Pump : $T = \frac{AH \times V \times 0.6}{P}$

T - Pump running time in hours
 P - Pump power in Watts
 V - Battery voltage
 AH - Ampere hour (Battery capacity)

Note : To get the desired Voltage to run the Solar Pumps suitable no. of batteries can be connected in series.

Eg. To run a 24V D.C. Solar Pump, 12V battery x 2nos. need to be connected in series.

Example 1 (Pump running time calculation)

If the pump power is 200W, the battery capacity is 100AH, the battery voltage is 12V and when the battery is fully charged, then the pumpset running hour is calculated as : $100 \times 0.6 / (200 / 12) = 3.6$ hours.

Example 2 (Battery capacity calculation)

If the pump power is 200W, the battery voltage is 12V, and the battery need to be used for 3.6 hours, then the battery capacity is calculated as : $(3.6 / 0.6) \times (200 / 12) = 100AH$.

Note : The storage battery and frames required for solar panel mounting have to be sourced at customer end or contact our authorized dealer.

In view of continuous developments, the information / descriptions / specifications / illustrations are subject to change without notice.