



**C.R.I. PUMPS**  
Pumping trust. Worldwide.

DEEP WELL  
SUBMERSIBLE PUMPS

---

**EVERGREEN SERIES - 50Hz**

---

# GENERAL INFORMATION

## Submersible Pumps

C.R.I. Submersible Pumps are the products of the expertise gained from over four decades of experience, endurance and workmanship. These products are engineered to perfection with utmost care and stringent quality control at all stages to ensure a trouble free service.

**Description :** C.R.I. 6" & 8" Evergreen Series Submersible pumps are available with different materials of construction. Pumps are incorporated with extremely hardwearing bearings and built in stainless steel check valve. All vital components of these pumps are designed for the best possible hydraulic efficiency.

All the bronze components are made of high grade "Zinc free bronze" to resist corrosion and to withstand wear & tear caused by sand. Also the high quality cast iron components and shaft made of S.S.431 ensures the long life of the pump. Pumps are multistage centrifugal type, which are firmly coupled to a submersible electric motor which operates submerged beneath the surface of water.

Built in check valve prevents back flow and reduces the risk of water hammering. All mounting dimensions of pumps & motors are accordance with NEMA standard. C.R.I. Submersible pumps can be offered with either C.R.I. 'W' Series water filled rewindable submersible motors or any other NEMA standard motors.

**Features :** Best operating efficiency | Extremely hardwearing water lubricated bearings | Highly durable | Water cooled rewindable motor | Can be easily dismantled and repaired | Can handle more upthrust loads.

**Applications :** Irrigation | Civil water supply | Fountains | Industrial & Rural water supply | Fire fighting | Pressure boosting units | Gardens | Sprinkler systems and Mining.



# EVERGREEN SERIES

## Model Identification Code

### MODEL IDENTIFICATION CODE DEEPWELL SUBMERSIBLE PUMP - 50 HZ

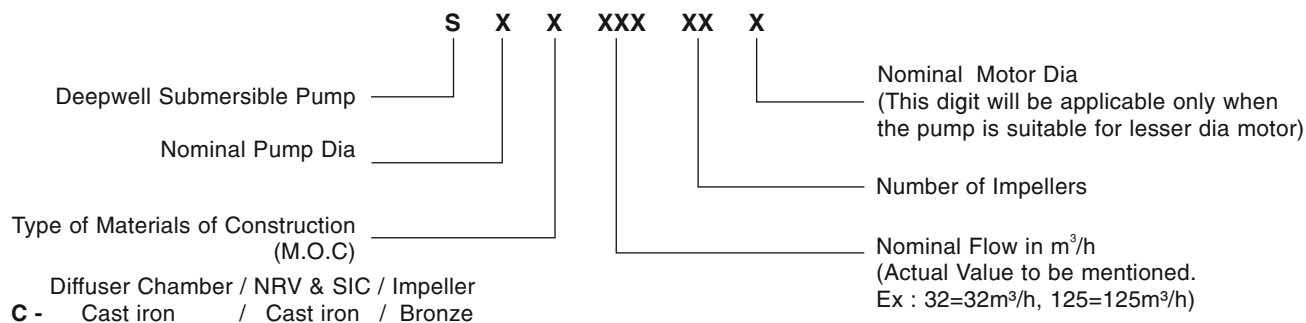

## Pumped Liquids

Clean, thin, non-aggressive, non explosive, clear, cold, fresh water without abrasives, solid particles or fibre having the following characteristics.

a)	Temperature	33°C (max.)
b)	Permissible amount of sand	50g/m <sup>3</sup> (max.)
c)	Chlorine ion density	500 ppm (max.)
d)	Allowable solids	3000 ppm (max.)
e)	Specific gravity	1.004 (max.)
f)	Hardness (Drinking water)	300 (max.)
g)	Viscosity	1.75 x 10 <sup>-6</sup> m <sup>2</sup> /sec (max.)
h)	Turbidity	50 ppm silica scale(max.)
i)	pH	6.5 to 8.5

### Maximum Temperature of Pumped Liquid

Motor	Minimum cooling flow along the motor	Vertical installation	Horizontal installation minimum 30° angle
6"	0.15 m/s	33°C	33°C
8"	0.16 m/s	33°C	33°C

Pump Operating Limitations			
Nominal diameter		6"(150mm)	8"(200mm)
Power Range		3.7 - 26 kW	5.5 - 93 kW
Speed		2900 rpm	2900 rpm
Discharge Range	m <sup>3</sup> /h	9 – 83	20 – 187
	lps	2.5 – 23	5.5 – 52
Total Head Range	m	2 – 272	3 – 375
	ft	6.5 – 892	9.8 – 1230
Outlet Size in Inches		3 & 4	3, 4, 5 & 6

Maximum operating pressure	
6" Submersible pump	2.7Mpa (27 bar)
8" Submersible pump	3.7Mpa (37bar)

# GENERAL INFORMATION

Group Performance Curve - 6" & 8"

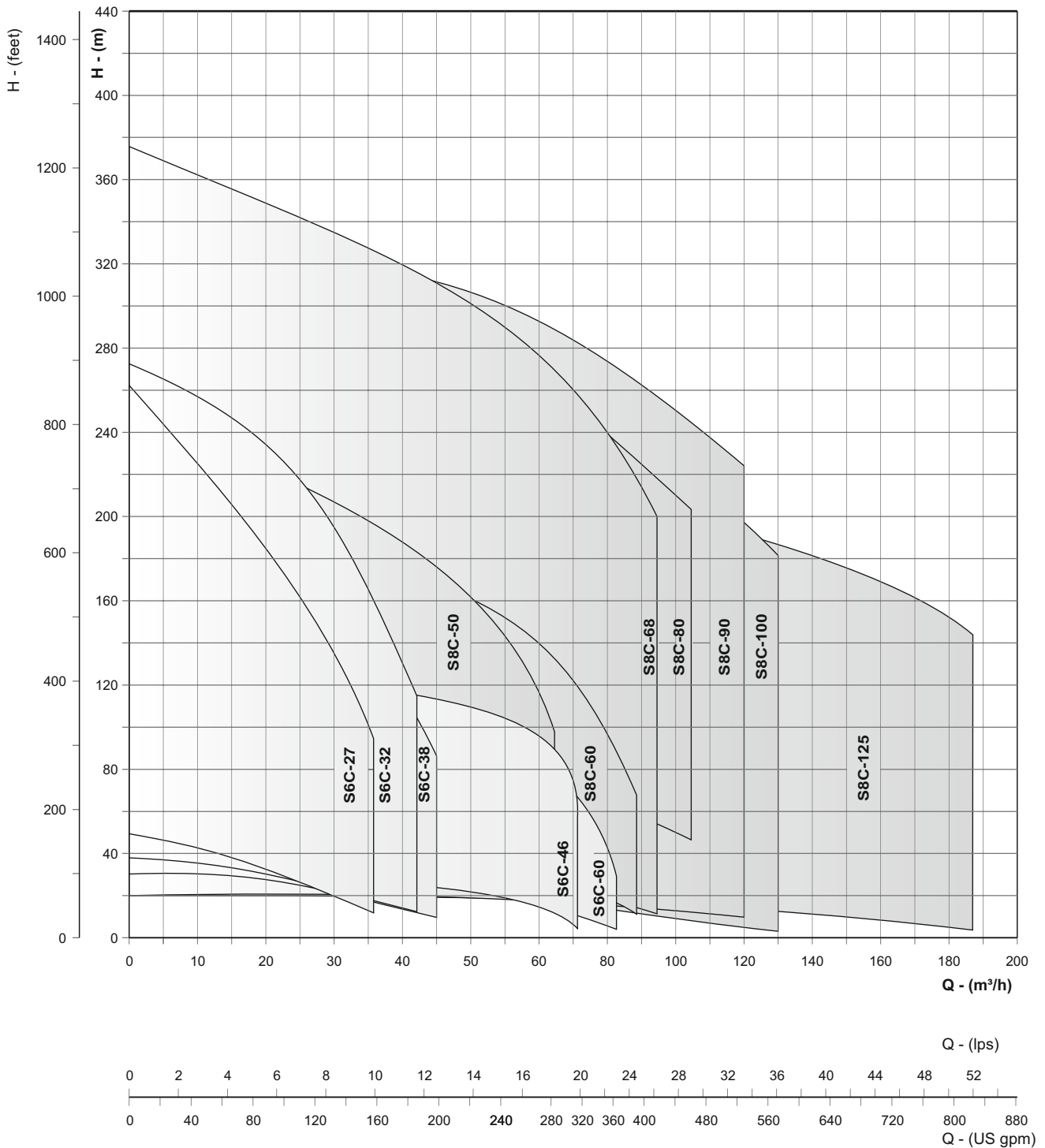

# EVERGREEN SERIES

## Materials of Construction

PART NAME	PART No.	NOMINAL DIA . 6"	NOMINAL DIA . 8"
		TYPE - C	TYPE - C
CHECK VALVE HOUSING	21.00	CAST IRON	CAST IRON
CHECK VALVE DISC	21.06	S.S - 304	S.G. IRON
CHECK VALVE SEAT	21.03	NBR	S.G. IRON
DIFFUSER CHAMBER	18.03	CAST IRON	CAST IRON
IMPELLER	19.00	BRONZE	BRONZE
WEARING RING	17.01	NBR	S.S - 304 / NBR
UP THRUST WASHER / STOP RING	13.03	S.S - 420 / BRONZE	SS 420 / BRONZE
INTERMEDIATE BEARING ( SLEEVE / BUSH )	18.06	S.S - 410 / BRONZE	S.S - 410 / BRONZE &
			S.S - 410 / NITRILE RUBBER
SUCTION INTER CONNECTOR	17.00	CAST IRON	CAST IRON
INLET SCREEN	14.03	S.S - 304	S.S - 304
PUMP SHAFT	22.00	S.S - 410 / 431	S.S - 431
CABLE GUARD	17.04	S.S - 304	S.S - 304
COUPLING	22.01	S.S - 329	S.S - 329

# GENERAL INFORMATION

## Cross-sectional Drawing

**6" TYPE - C**

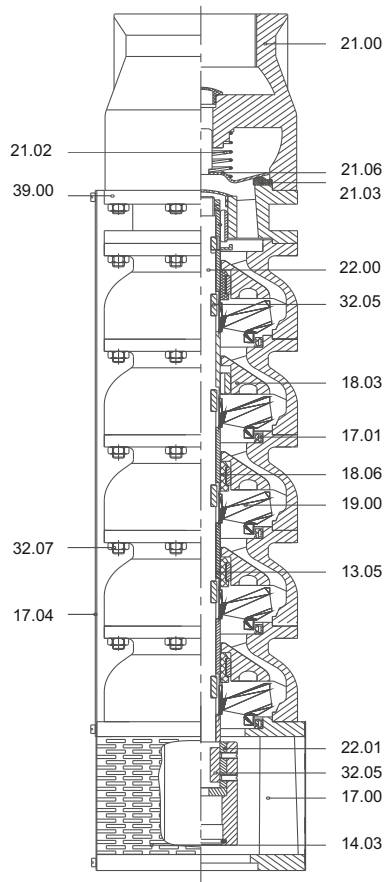

**8" TYPE - C**

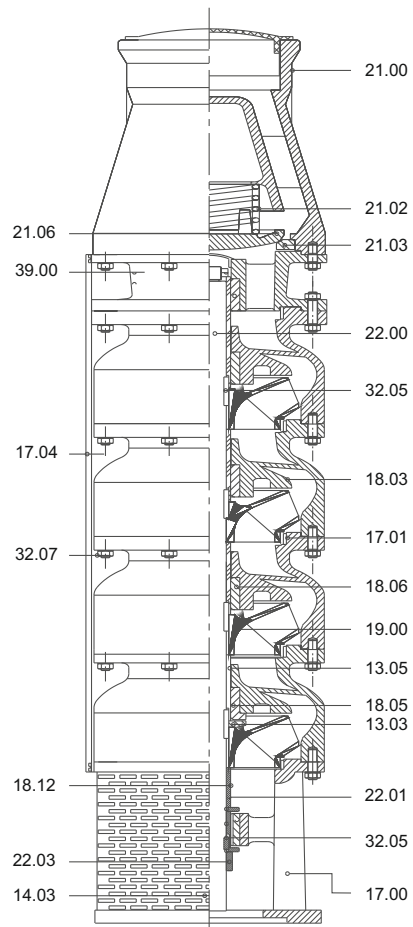

Part No.	Part Name
13.03	Upthrust Washer / Stopring
13.05	Sleeve
14.03	Inlet Screen
17.00	Suction Inter Connector
17.01	Wearing Ring
17.04	Cable Guard
18.03	Diffuser Chamber

Part No.	Part Name
18.05	Upthrust Pad
18.06	Bush
18.12	Spacer
19.00	Impeller
21.00	Check Valve Housing
21.02	Check Valve Spring
21.03	Check Valve Seat

Part No.	Part Name
21.06	Check Valve Disc
22.00	Pump Shaft
22.01	Coupling
32.05	Key
32.07	Nut
39.00	Bush Bracket