

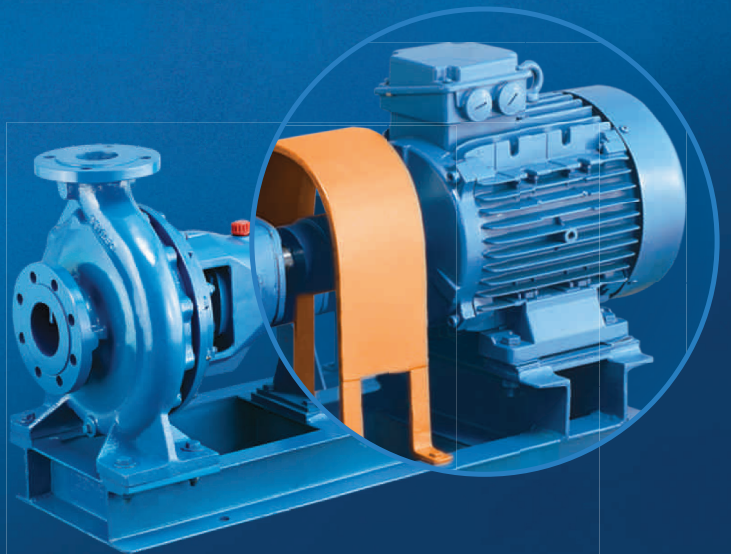

End Suction Centrifugal Pumps

EC SERIES





C.R.I. PUMPS
Pumping trust. Worldwide.

Vision, Mission and Values

To be the industry leader providing best - in - class fluid management solutions to individual and institutional customers and societies in our chosen markets.

We will achieve this through our dedicated efforts to enhance the welfare of all our stakeholders and by living by our values of **commitment, reliability** and **innovation**.



C.R.I. PUMPS

Pumping trust. Worldwide.

T H E B E G I N N I N G

of C.R.I., way back in 1961, was a resolute attempt to produce a few irrigation equipments using the limited facilities of an in-house foundry. Eventually the founder's dream was coming true as the small production unit he started kept growing rapidly. Now, after more than five eventful decades, it is an enormous, widely reputed organization, which produces more than 1000 varieties of perfectly engineered pumps and motors and sells its products in numerous countries spread across 6 continents.

C . R . I . I S O N E A M O N G

the few pioneers in the world to produce 100% stainless steel submersible pumps. Having achieved a record production capacity of over one million pumps per annum, today C.R.I. is rubbing its shoulders with the best brands in the world, with advanced technology and safety standards as its hallmarks.

T H E I N F R A S T R U C T U R E

of C.R.I. is pretty comprehensive with state-of-the-art machineries and a high potential in-house R&D recognised by the ministry of science and technology, Govt. of India - all within its own covered area of 150,000 square metres. The production environment is accredited with ISO 9001 & 14001 certifications and the product are CE, UR/UL, TSE & ISI Certified. The R&D team always stays in tune with the changing scenario and seldom fails in coming up with outstanding solutions every time.

N E E D L E S S T O S A Y ,

behind this legendary growth lies the untiring, innovative, enthusiastic and dedicated team work. And, of course, a flawlessly maintained value system too. The name C.R.I. itself encapsulates the company's ethos: " Commitment, Reliability, Innovation".

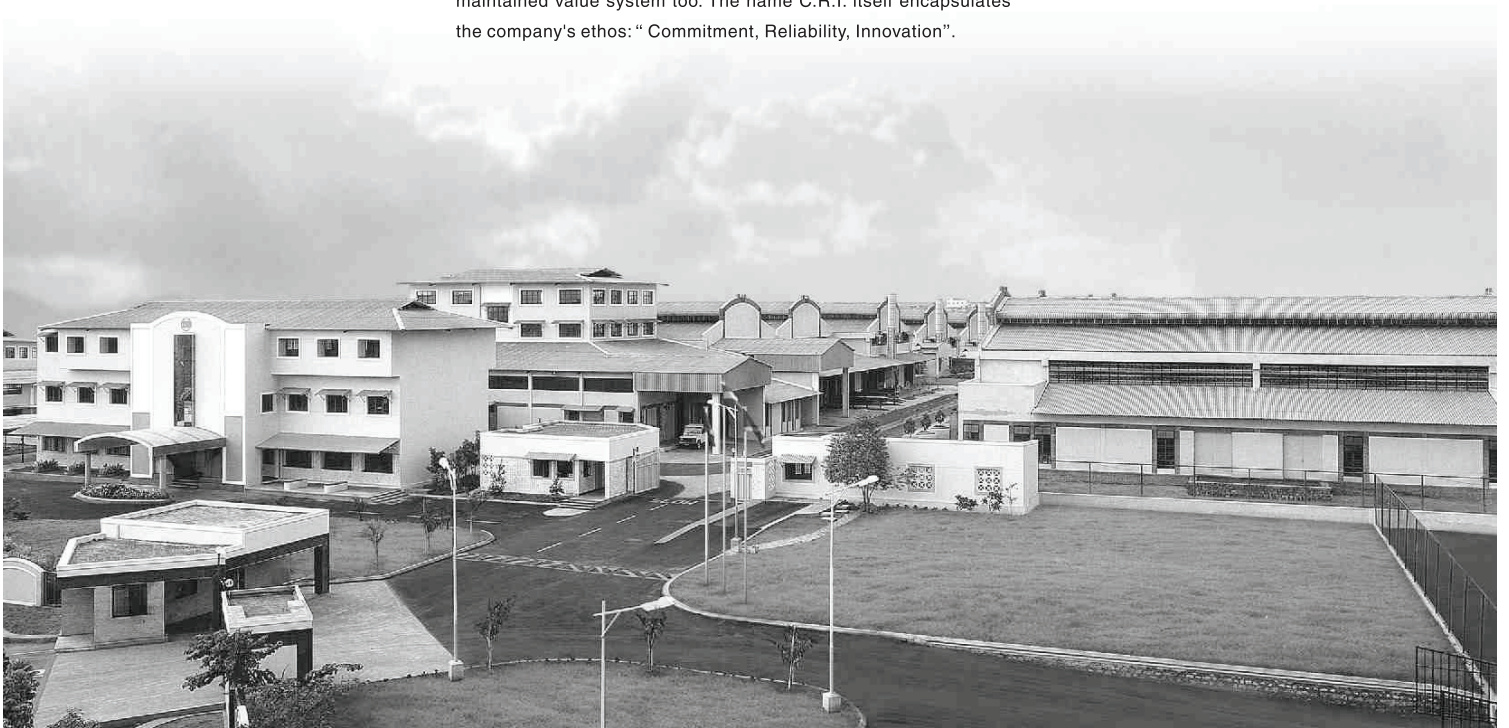

GENERAL INFORMATION - ECW SERIES

MODEL IDENTIFICATION CODE

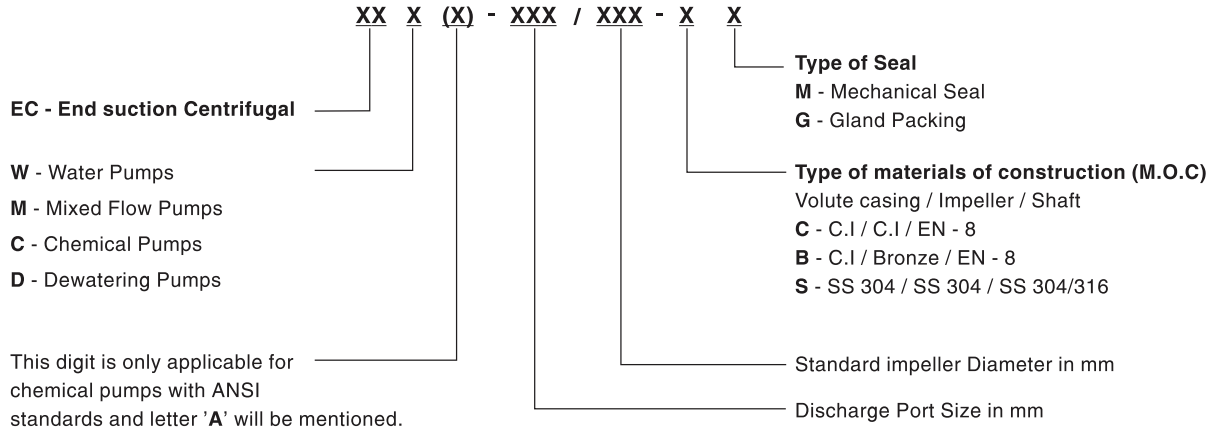

C O N T E N T S

	Page No.
ECW Series	
General Information	
Construction, Features & Applications	4
Operating limits & MOC	5
Group Performance Curves	6
Overall Dimensional Drawing	8
Overall Dimensions	9
Cross Sectional Drawings	10
Stuffing Box Details	11
Performance curves	12
ECM Series	
General Information	
Construction, Features & Applications	78
Operating limits, MOC & Technical Data	79
Cross Sectional Drawings	80
Overall Dimensional Drawings & Performance curves	82

GENERAL INFORMATION - ECW SERIES

End Suction Centrifugal Pumps



CONSTRUCTION

C.R.I. End suction pumps are single stage centrifugal, non-self priming, volute pumps. These pumps features horizontal shaft components with axial suction and impellers and radial discharge ports. Pumps volute chamber and impellers are carefully designed to give the best possible and suction lift characteristics.

Most modern and highly sophisticated machinery and technology are employed in the manufacture of these pumps using quality raw material, dynamically balanced impellers, seal and bearings to ensure long life.

FEATURES

- Designed to allow interchangeability of their component between all individual pump sizes.
- Minimizes shaft deflection maximizes bearing and mechanical seal life.
- Heavy duty bearing ensures long life.
- Back pull out design facilitates dismantling the pump without disconnecting the pump casing from the pipes.
- Dimensions and characteristics according to DIN 24255 standards (On request - ISO 2858 standards pumps can be supplied).
- Available both in mechanical seal and soft packed stuffing box design.

APPLICATIONS

- Water supply
- Irrigation
- Pressure boosting
- Fire protection
- Heating and air conditioning systems
- Circulation and transfer of clean, chemically non-aggressive water and liquids
- General industrial services
- Water supply to swimming pool, fountains.

GENERAL INFORMATION - ECW SERIES

END SUCTION CENTRIFUGAL PUMPS

OPERATING LIMITS

Outlet size range : DN32 to DN150mm.

Flow range : Upto 550 m³/h

Total Head range : Upto 100m

Operating temperature with soft packed stuffing box : 90°C

Operating temperature with mechanical seal : 90°C

Maximum working pressure : 16bar

MATERIALS OF CONSTRUCTION

Pump Parts	Type - C	Type - B	Type - S
Pump casing	Cast iron	Cast iron	SS 304
Impellers	Cast iron	Bronze	SS 304
Shaft	EN - 8	EN - 8	SS 304 / 316
Sleeve	SS 410	SS 410	SS 410

GENERAL INFORMATION - ECW SERIES

GROUP PERFORMANCE CURVES

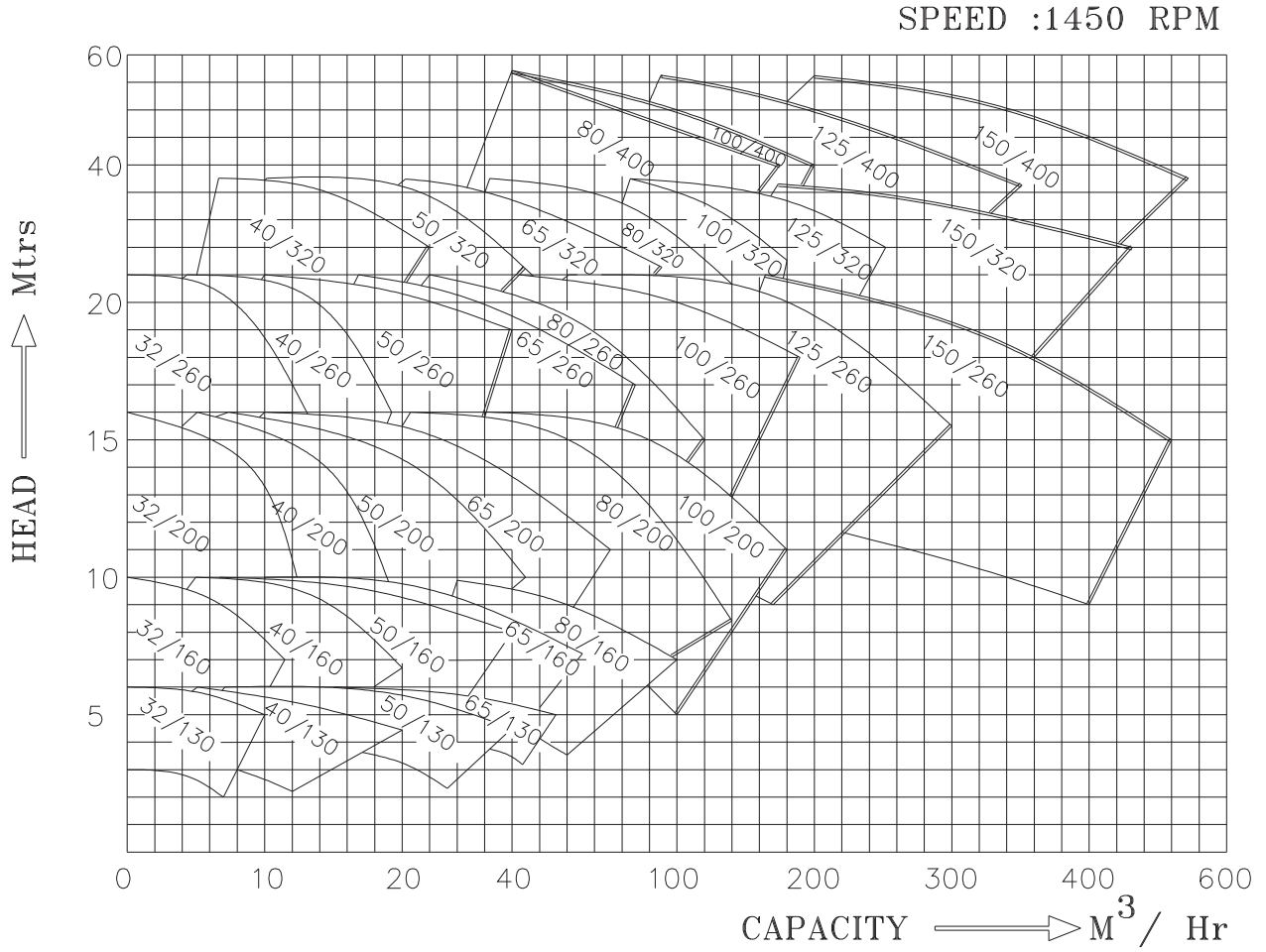

GENERAL INFORMATION - ECW SERIES

GROUP PERFORMANCE CURVES

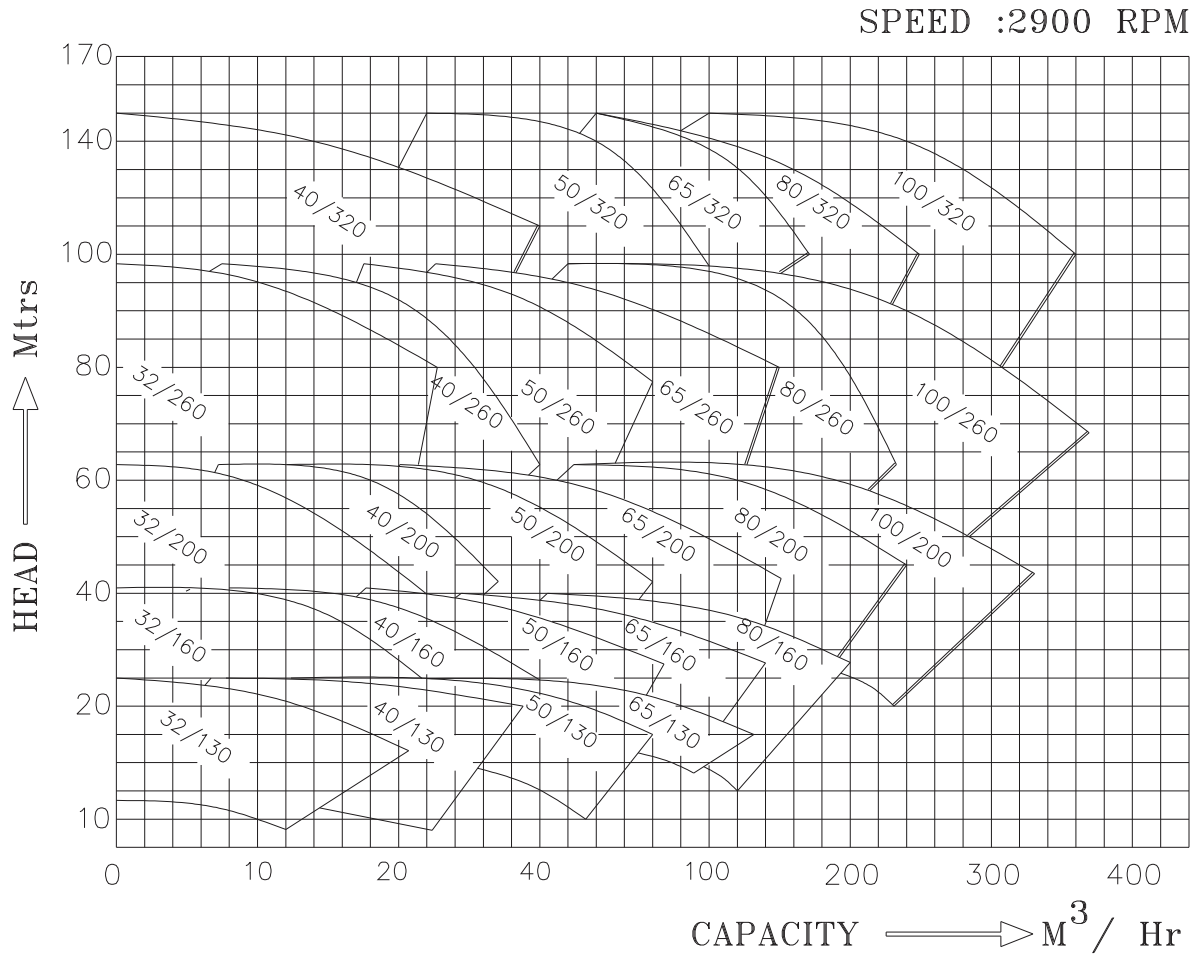

GENERAL INFORMATION - ECW SERIES

OVERALL DIMENSIONAL DRAWING

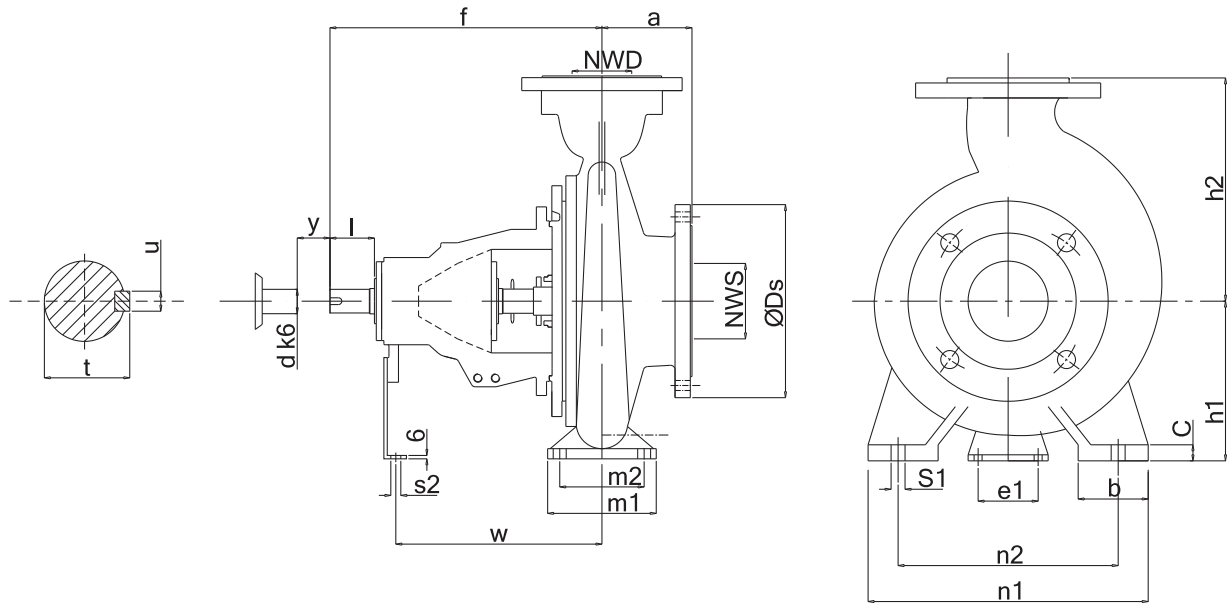

Centrifugal pumps with volute casing ND10/16 DIN 2532/ 2533 single stage end suction with bearing housing, Dimensions in accordance with DIN 24255.

Note :- Pump with impeller OD above 260mm at 2900 rpm not recommended. On specific demand, pump can be supplied with the strengthened shaft and bearing to run at 2900 rpm.

GENERAL INFORMATION - ECW SERIES

OVERALL DIMENSIONS

PUMP SIZE	SHAFT SIZE	PUMP DIMENSION																SHAFT END					DISTANCE	Pump Weight (kg)
		NWD	NWS	a	f	h1	h2	b	c	m1	m2	n1	n2	s1	e1	s2	w	d	l	t	u	y		
32/130	15W	32	50	80	360	112	140	50	14	100	70	190	140	14	100	14	267	24	50	27	8	140	45	
32/160	15W	32	50	80	360	132	160	50	14	100	70	240	190	14	100	14	267	24	50	27	8	140	50	
32/200	15W	32	50	80	360	160	180	50	14	100	70	240	190	14	100	14	267	24	50	27	8	140	60	
32/260	15W	32	50	100	360	180	225	65	14	125	95	320	250	14	100	14	267	24	50	27	8	140	74	
40/130	15W	40	65	80	360	112	140	50	14	100	70	210	160	14	100	14	267	24	50	27	8	140	50	
40/160	15W	40	65	80	360	132	160	50	14	100	70	240	190	14	100	14	267	24	50	27	8	140	58	
40/200	15W	40	65	100	360	160	180	50	14	100	70	265	212	14	110	14	267	24	50	27	8	140	66	
40/260	15W	40	65	100	360	180	225	65	14	125	95	320	250	14	110	14	267	24	50	27	8	140	85	
40/320	18W	40	65	125	470	200	250	65	14	125	95	345	280	14	110	14	342	32	80	35	10	140	-	
50/130	15W	50	65	100	360	132	160	50	14	100	70	240	190	14	110	14	267	24	50	27	8	140	60	
50/160	15W	50	65	100	360	160	180	50	14	100	70	265	212	14	110	14	267	24	50	27	8	140	61	
50/200	15W	50	65	100	360	160	200	50	14	100	70	265	212	14	110	14	267	24	50	27	8	140	68	
50/260	15W	50	65	100	360	180	225	65	14	125	95	320	250	14	110	14	267	24	50	27	8	140	89	
50/320	18W	50	80	125	470	225	280	65	14	125	95	345	280	14	110	14	342	32	80	35	10	140	-	
65/130	15W	65	80	100	360	160	180	65	14	125	95	280	212	14	110	14	267	24	50	27	8	140	65	
65/160	15W	65	80	100	360	160	200	65	14	125	95	280	212	14	110	14	267	24	50	27	8	140	69	
65/200	15W	65	80	100	360	180	225	65	14	125	95	320	250	14	110	14	267	24	50	27	8	140	81	
65/260	18W	65	80	100	470	200	250	80	16	160	120	360	280	18	110	14	342	32	80	35	10	140	107	
65/320	18W	65	80	125	470	225	280	80	16	160	120	400	315	18	110	14	342	24	50	35	10	140	132	
80/160	15W	80	100	125	360	180	225	65	14	125	95	320	250	14	110	14	267	24	50	27	8	140	79	
80/200	18W	80	100	125	470	180	250	65	14	125	95	345	280	14	110	14	342	32	80	35	10	140	104	
80/260	18W	80	100	125	470	200	280	80	16	160	120	400	315	18	110	14	342	32	80	35	10	140	122	
80/320	18W	80	100	125	470	250	315	80	16	160	120	400	315	18	110	14	342	32	80	35	10	140	159	
80/400	22w	80	125	140	530	280	355	100	18	200	150	500	400	23	110	14	370	42	110	45	12	140	-	
100/200	18W	100	125	125	470	200	280	80	16	160	120	360	280	18	110	14	342	32	80	35	10	140	99	
100/260	18W	100	125	140	470	225	280	80	16	160	120	400	315	18	110	14	342	32	80	35	10	140	130	
100/320	18W	100	125	140	470	250	315	80	16	160	120	400	315	18	110	14	342	32	80	35	10	140	169	
100/400	22W	100	125	140	530	280	355	100	18	200	150	500	400	23	110	14	370	42	110	45	12	140	221	
125/260	18W	125	150	140	470	250	355	80	16	160	120	400	315	18	110	14	342	32	80	35	10	140	136	
125/320	22W	125	150	140	530	280	355	100	18	200	150	500	400	23	110	14	370	42	110	45	12	140	197	
125/400	22W	125	150	140	530	315	400	100	18	200	150	500	400	23	110	14	370	42	110	45	12	140	246	
150/260	22W	150	200	160	530	280	400	100	18	200	150	500	400	23	110	14	370	42	110	45	12	140	197	
150/320	22W	150	200	160	530	280	400	100	18	200	150	550	450	23	110	14	370	42	110	45	12	140	257	
150/400	22W	150	200	160	530	315	450	100	18	200	150	550	450	23	110	14	370	42	110	45	12	140	300	
Back pull out distance required between driver shaft end pump shaft																								
DIMENSIONS OF FLANGE CONNECTIONS																								
NWD/NWS	32		40		50		65		80		100		125		150		200							
D	140		150		165		191		200		235		270		300		360							
K	100		110		125		145		160		180		210		240		295							
d²XNos	18X4		18X4		18X4		18X8		18X4		18X4		18X8		22X8		22X12							

GENERAL INFORMATION - ECW SERIES

CROSS SECTIONAL DRAWING

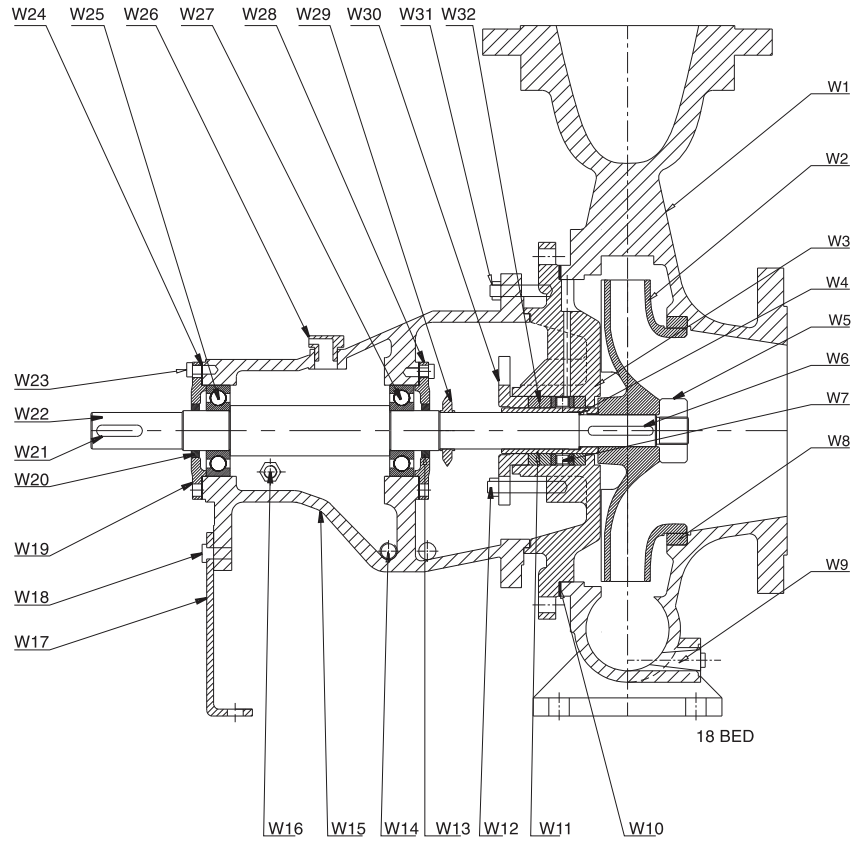

ALTERNATIVE TYPES OF SHAFT SEALS

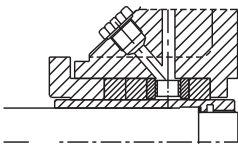

External flushing uncooled stuffing box
Stuffing box for external sealing
drilled inlet and outlet

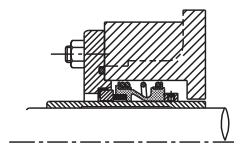

With Meachanical seal

CODE NO	PART NAME	MATERIAL	QTY
W1	PUMP CASING		1
W2	IMPELLER		1
W3	STUFFING BOX		1
W4	GASKET (IMP/SLEEVE)		1
W5	IMPELLER NUT		1
W6	KEY IMPELLER	BS 970 EN8	1
W7	LANTERN RING		1
W8	WEAR RING		1
W9	CASING PLUG (DRAIN)		1
W10	GASKE (ST.BOX/ CASING)		1
W11	SLEEVE		1
W12	STUD (GLAND / S.BOX)		1
W13	OIL SEAL (INNER)		1
W14	PLUG OIL DRAIN	BS 970 EN8	1
W15	BEARING HOUSING	IS 210 FG200	1
W16	OIL LEVEL SIDE GLASS	ALUMINIUM	1
W17	SUPPORT FOOT	IS 226 C15	1
W18	BOLT (SUPPORT / BED)		1
W19	BEARING COVER OUTER	IS 210 FG200	1
W20	OIL SEAL (OUTER)		1
W21	KEY COUPLING	BS 970 EN8	1
W22	SHAFT		1
W23	BOLT (OUTER COVER / BED)		1
W24	GASKET(OUTER COVER/BED)		1
W25	BEARING COUPLING END	STEEL	1
W26	VENT	PP	1
W27	BEARING PUMP END	STEEL	1
W28	BEARING COVER INNER	IS 210 FG200	1
W29	DEFLECTOR		1
W30	GLAND		1
W31	STUD (BED /S.BOX)		1
W32	GLAND PACKING	TIGA / PTFE	1 SET

GENERAL INFORMATION - ECW SERIES

STUFFING BOX DETAILS

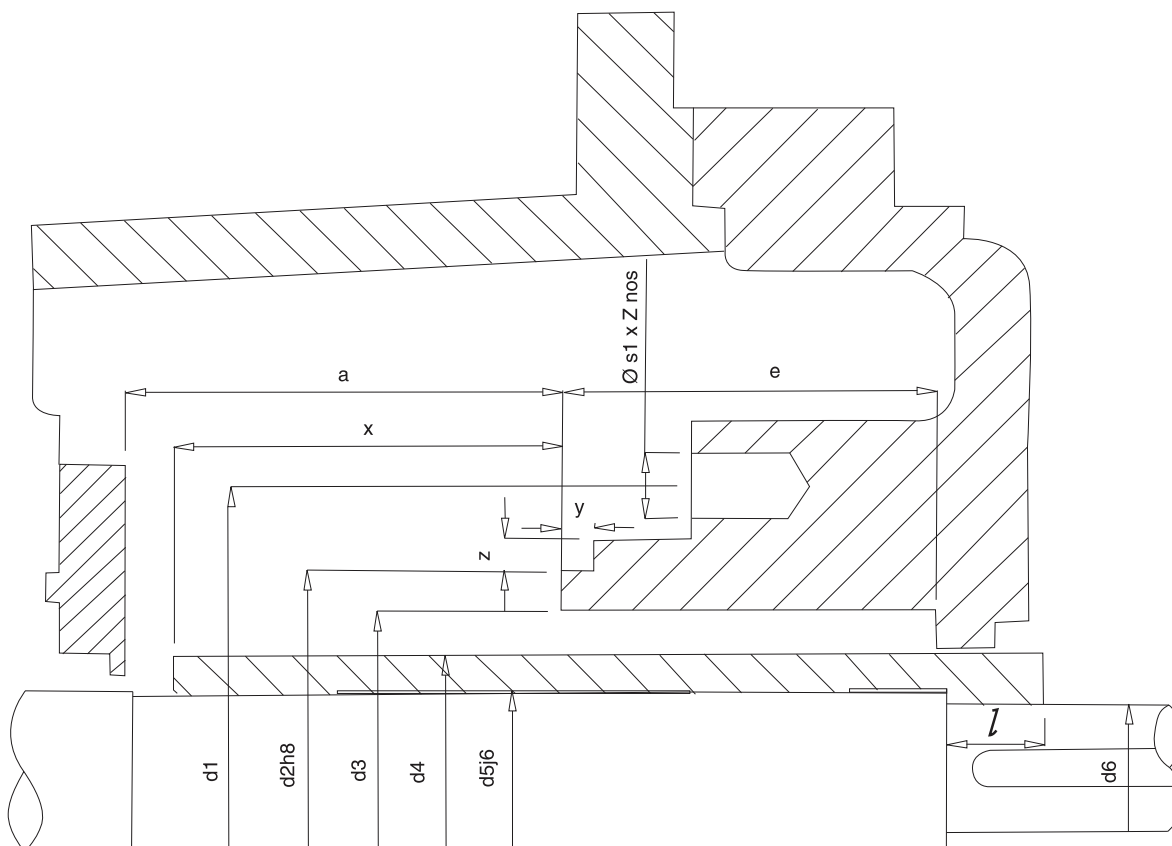

All Dimensions are in mm

BEARING UNIT	a	e	d1	z x s1	d2	d3	d4 mm-in	d5	d6	∠	h	l	k
15 H	56	51	85	4XM10	62	48	32	24	20	14	21.6	6	10
18 H	70	64	100	4XM12	76	60	40	32	28	17	29.7	8	13
22H	80	64	110	4XM12	86	70	50	43	38	17	40.3	10	13



PERFORMANCE CURVE

Model : ECW-32/130

Note : Performance curve are as per specific gravity and viscosity of water.

SIZE : 50 x 32

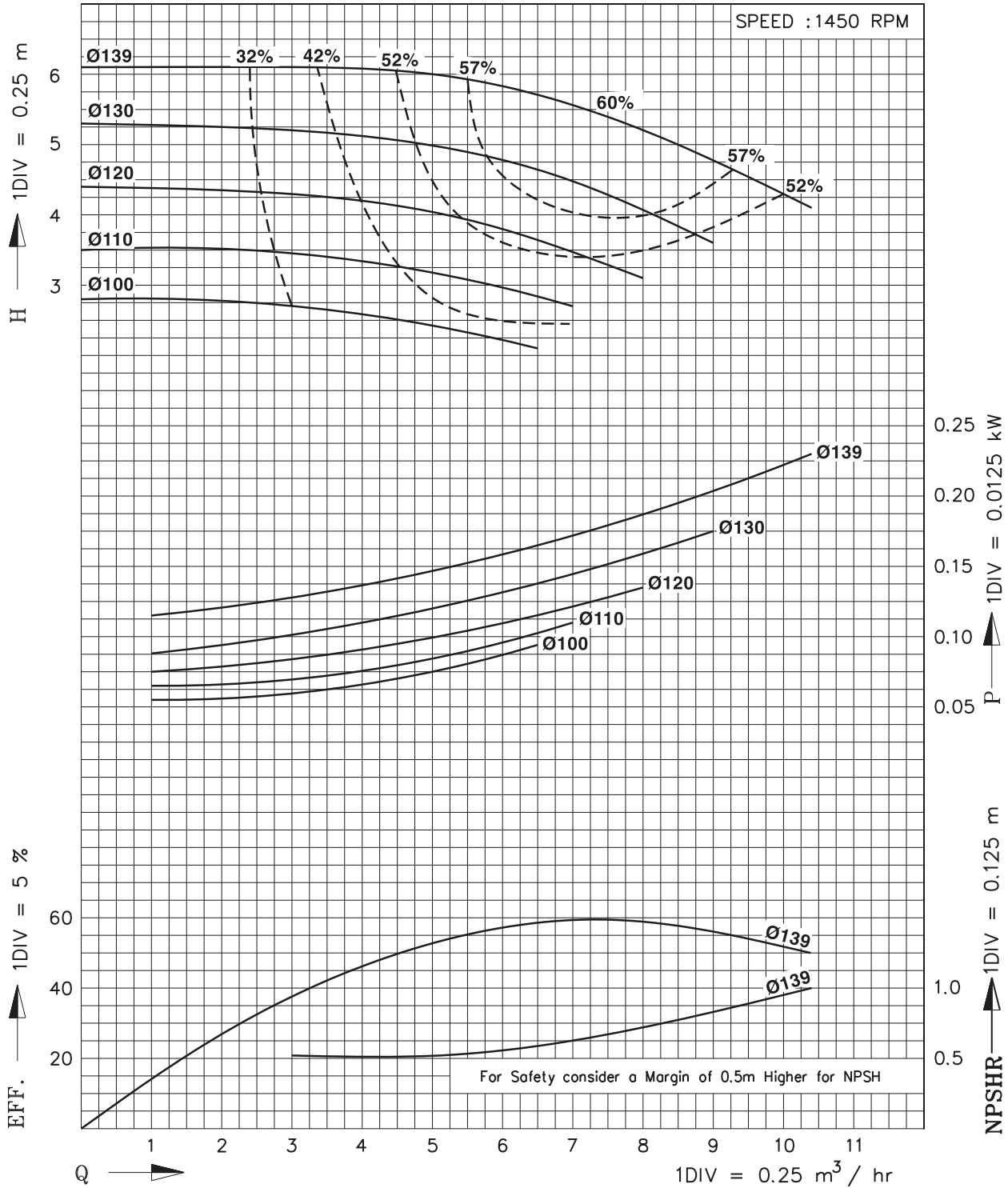

In view of continuous developments the information / performance / descriptions / specifications / Illustrations mentioned in this catalogues are subject to change without notice.



PERFORMANCE CURVE

Model : ECW-32/130

Note : Performance curve are as per specific gravity and viscosity of water.

SIZE : 50 x 32

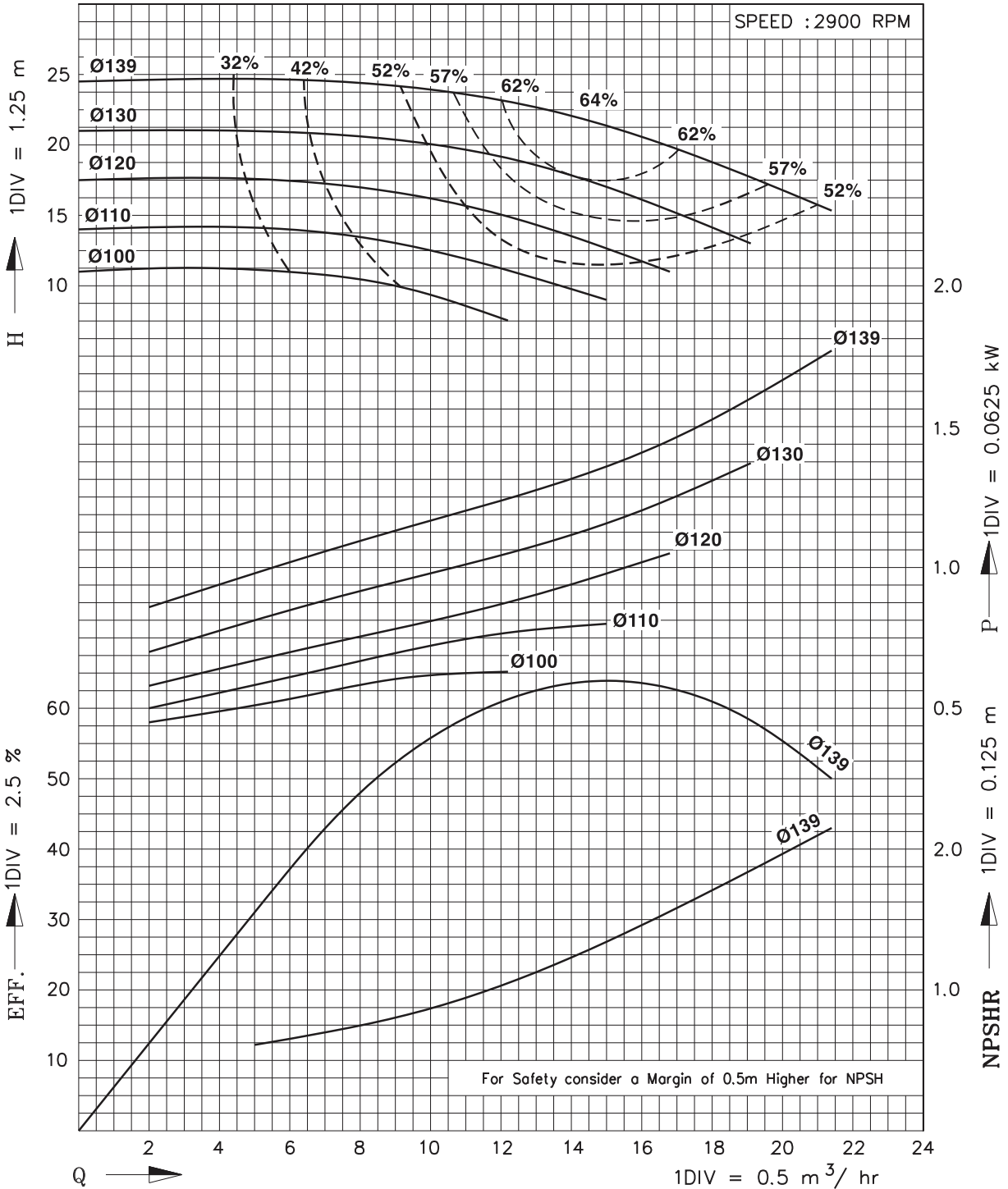



PERFORMANCE CURVE

Model : ECW-32/160

Note : Performance curve are as per specific gravity and viscosity of water.

SIZE : 50 x 32

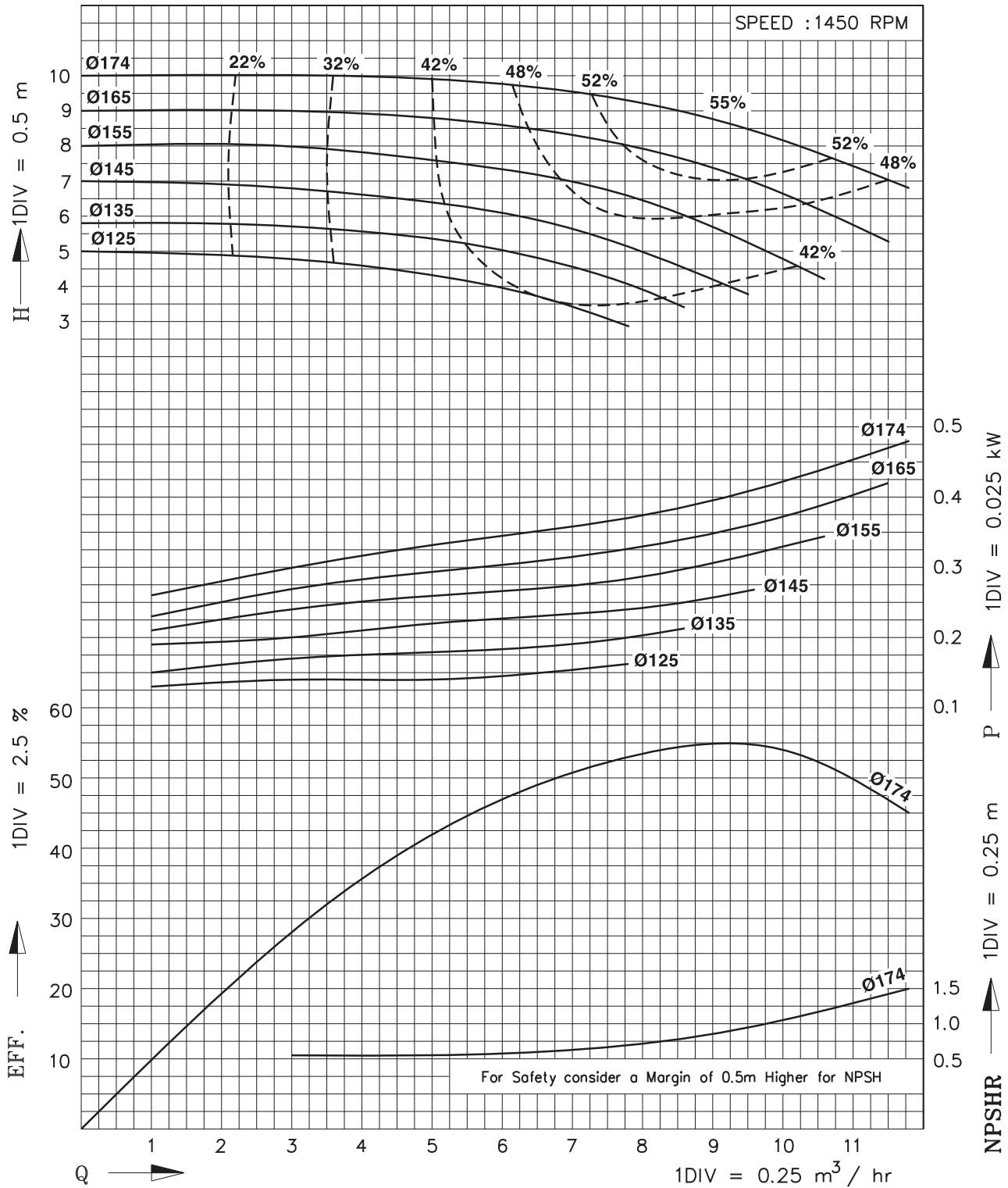

In view of continuous developments the information / performance / descriptions / specifications / Illustrations mentioned in this catalogues are subject to change without notice.



PERFORMANCE CURVE

Model : ECW-32/160

Note : Performance curve are as per specific gravity and viscosity of water.

SIZE : 50 x 32

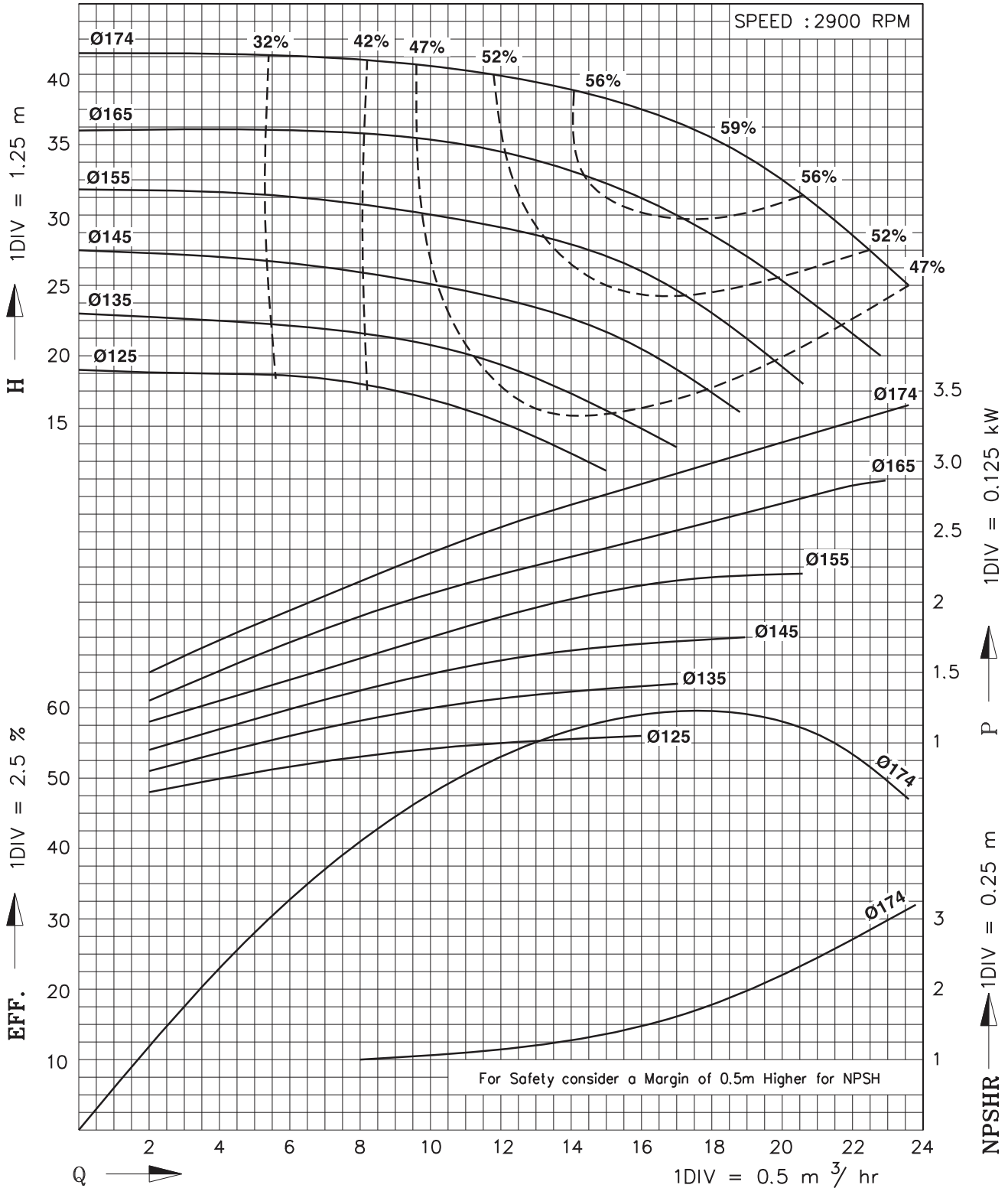

In view of continuous developments the information / performance / descriptions / specifications / Illustrations mentioned in this catalogues are subject to change without notice.



PERFORMANCE CURVE

Model : ECW-32/200

Note : Performance curve are as per specific gravity and viscosity of water.

SIZE : 50 x 32

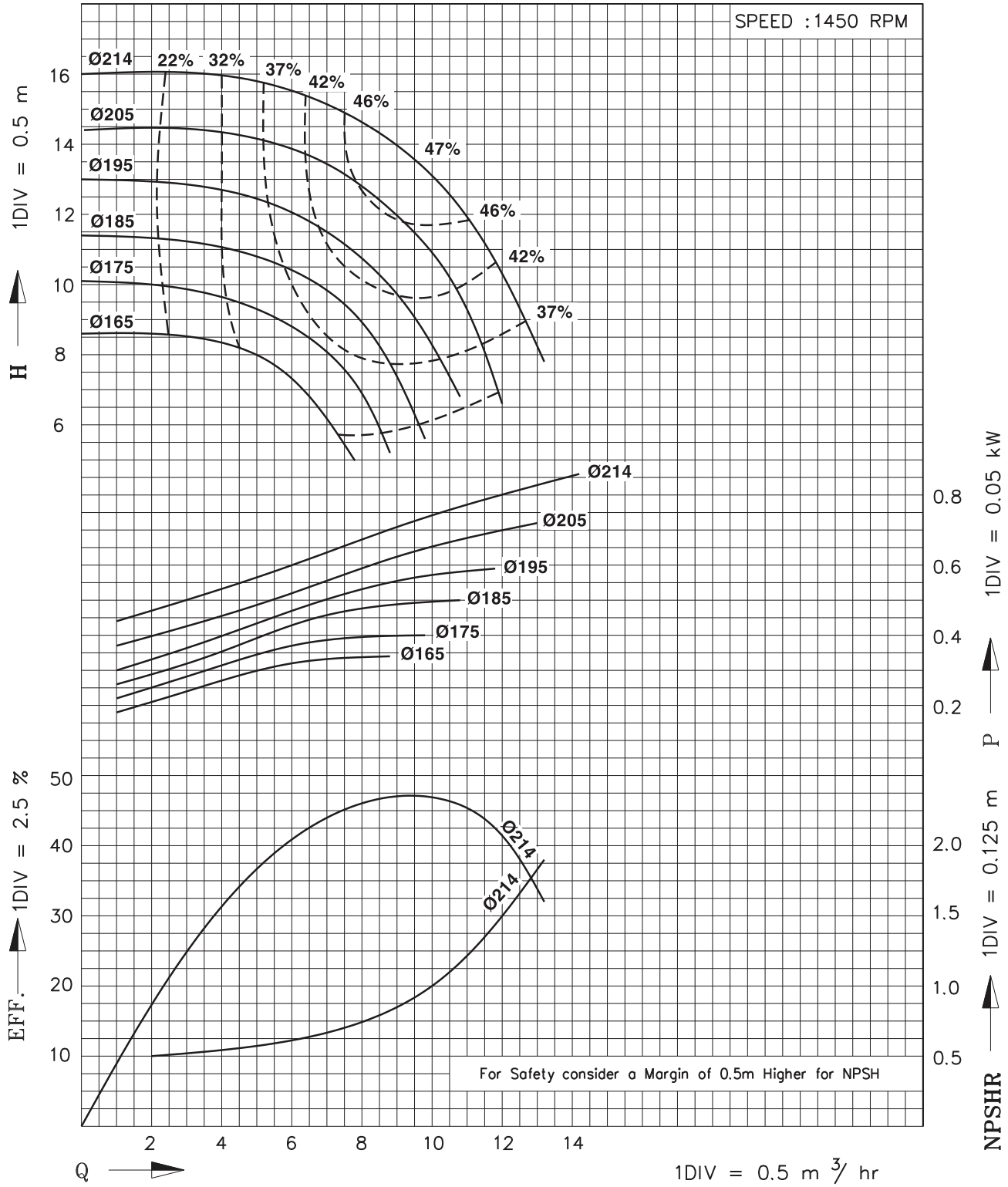

In view of continuous developments the information / performance / descriptions / specifications / Illustrations mentioned in this catalogues are subject to change without notice.



PERFORMANCE CURVE

Model : ECW-32/200

Note : Performance curve are as per specific gravity and viscosity of water.

SIZE : 50 x 32

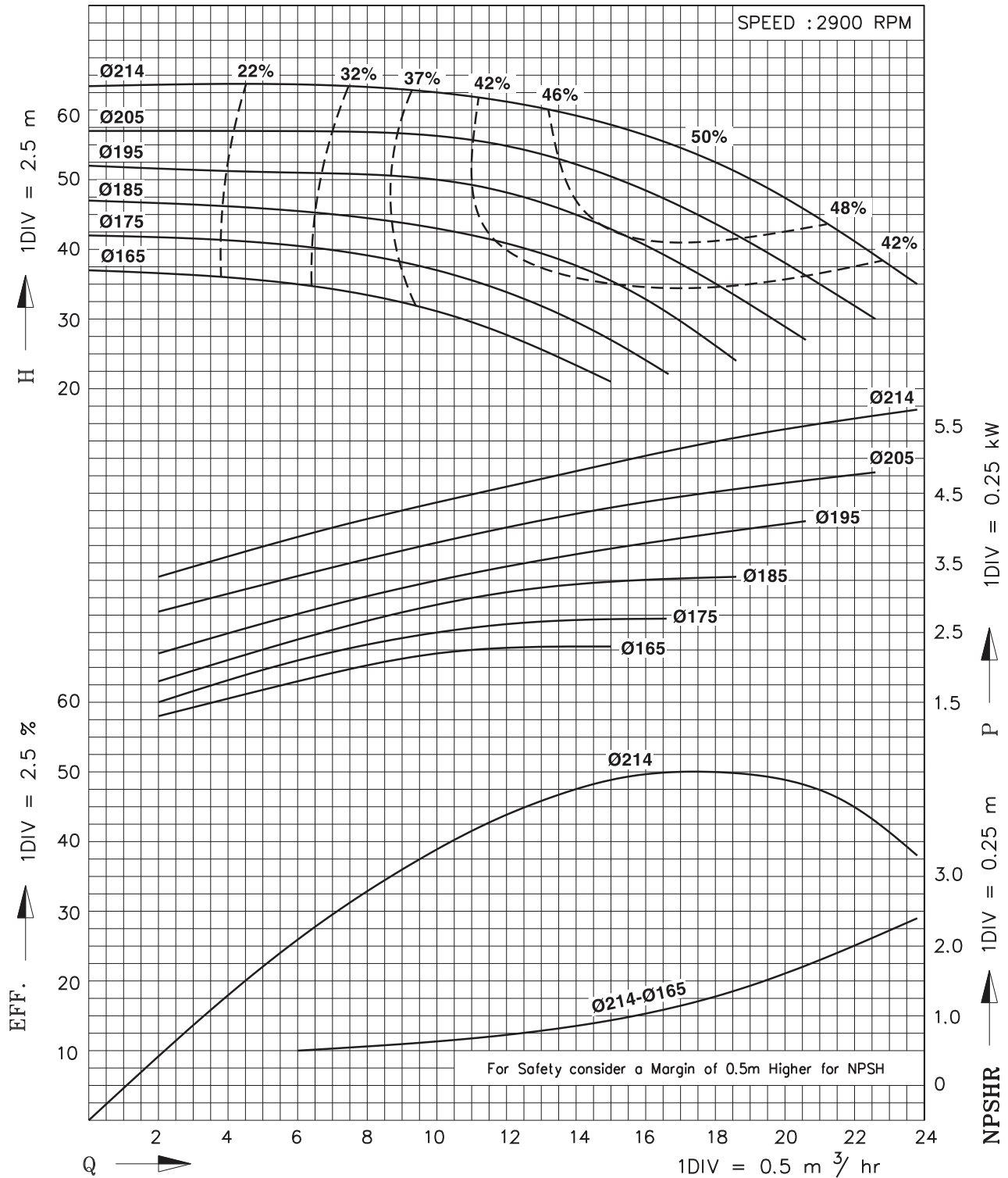



PERFORMANCE CURVE

Model : ECW-32/260

Note : Performance curve are as per specific gravity and viscosity of water.

SIZE : 50 x 32

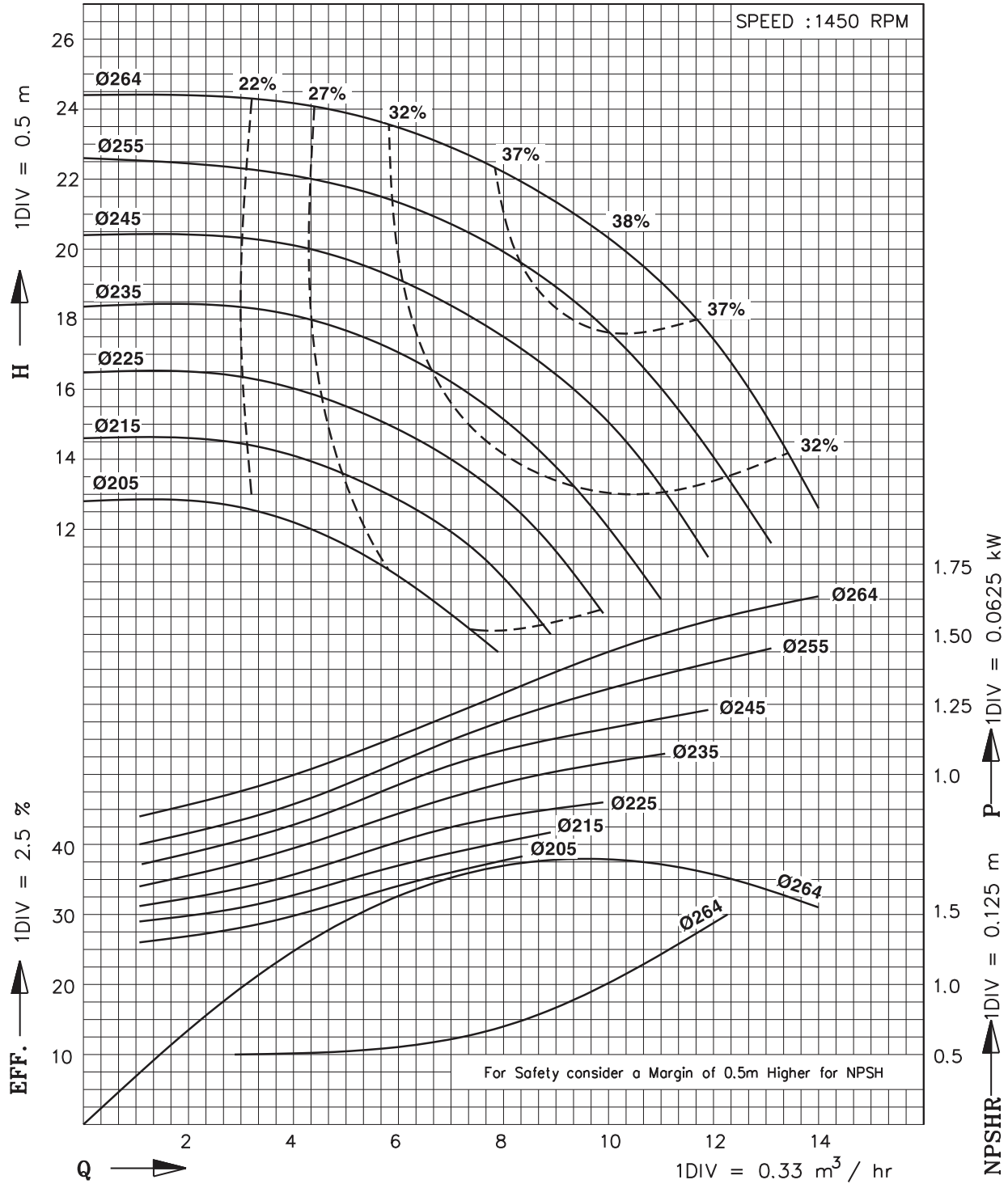



PERFORMANCE CURVE

Model : ECW-32/260

Note : Performance curve are as per specific gravity and viscosity of water.

SIZE : 50 x 32

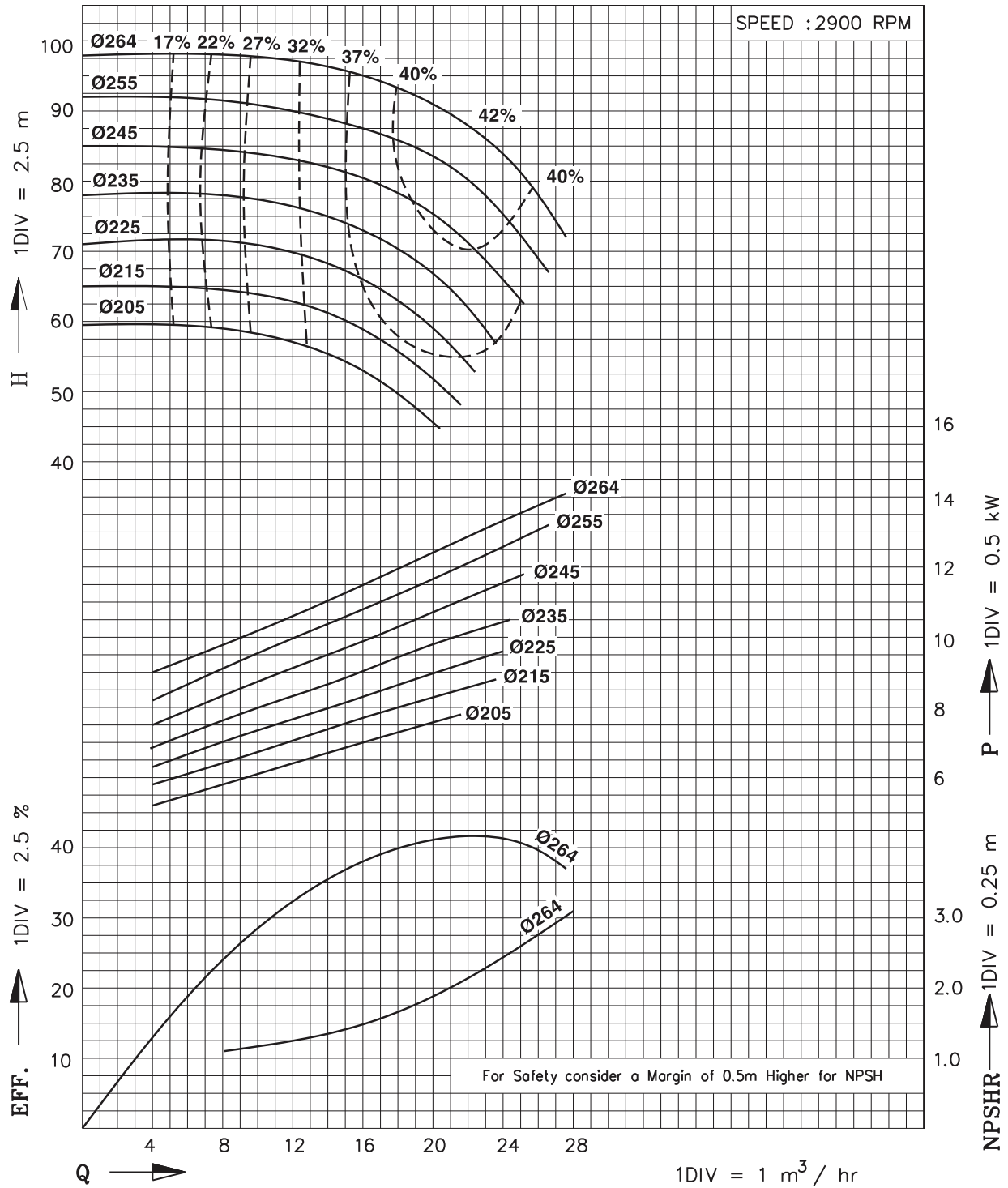



PERFORMANCE CURVE

Model : ECW-40/130

Note : Performance curve are as per specific gravity and viscosity of water.

SIZE : 65 x 40

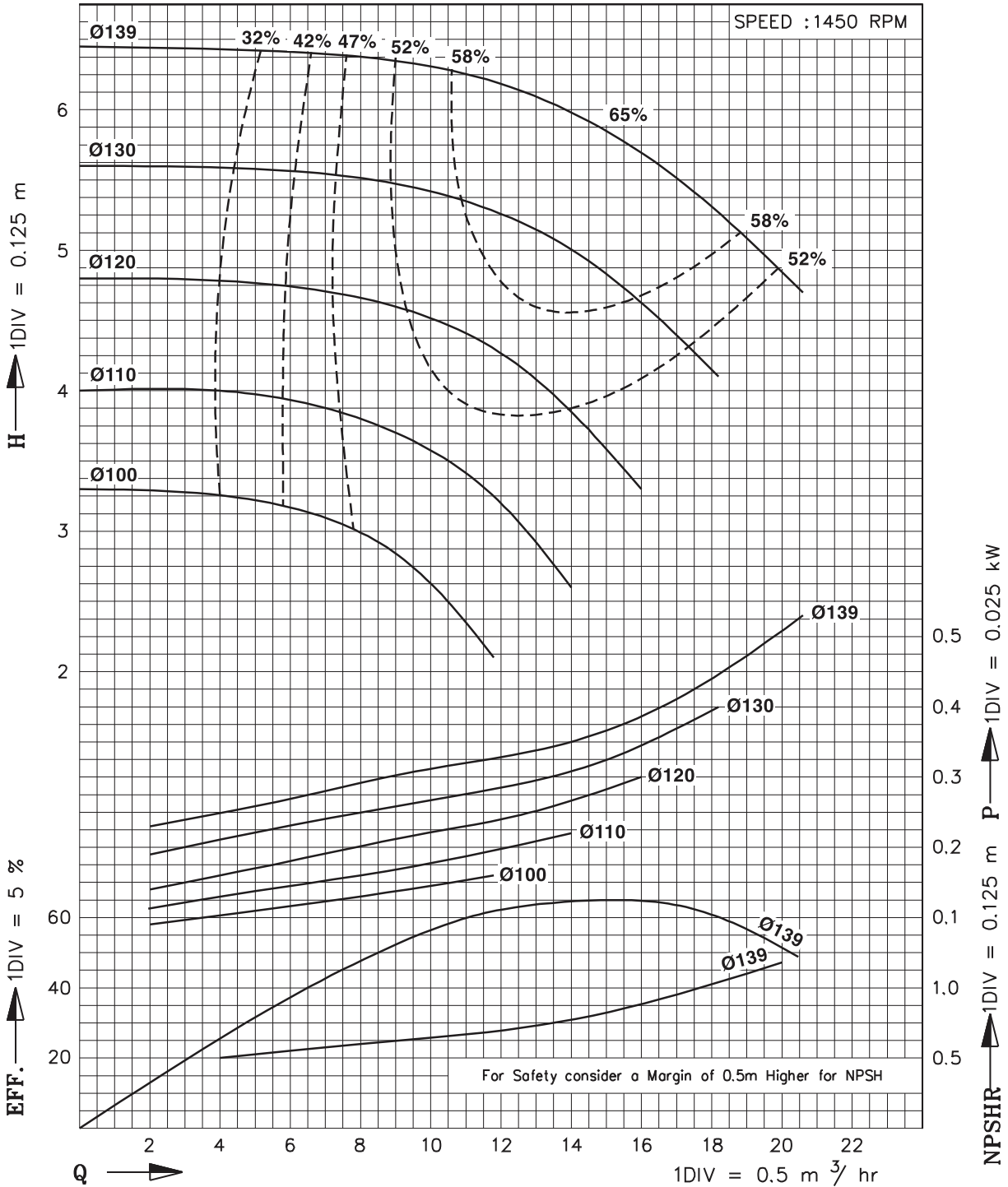

In view of continuous developments the information / performance / descriptions / specifications / Illustrations mentioned in this catalogues are subject to change without notice.



PERFORMANCE CURVE

Model : ECW-40/130

Note : Performance curve are as per specific gravity and viscosity of water.

SIZE : 65 x 40

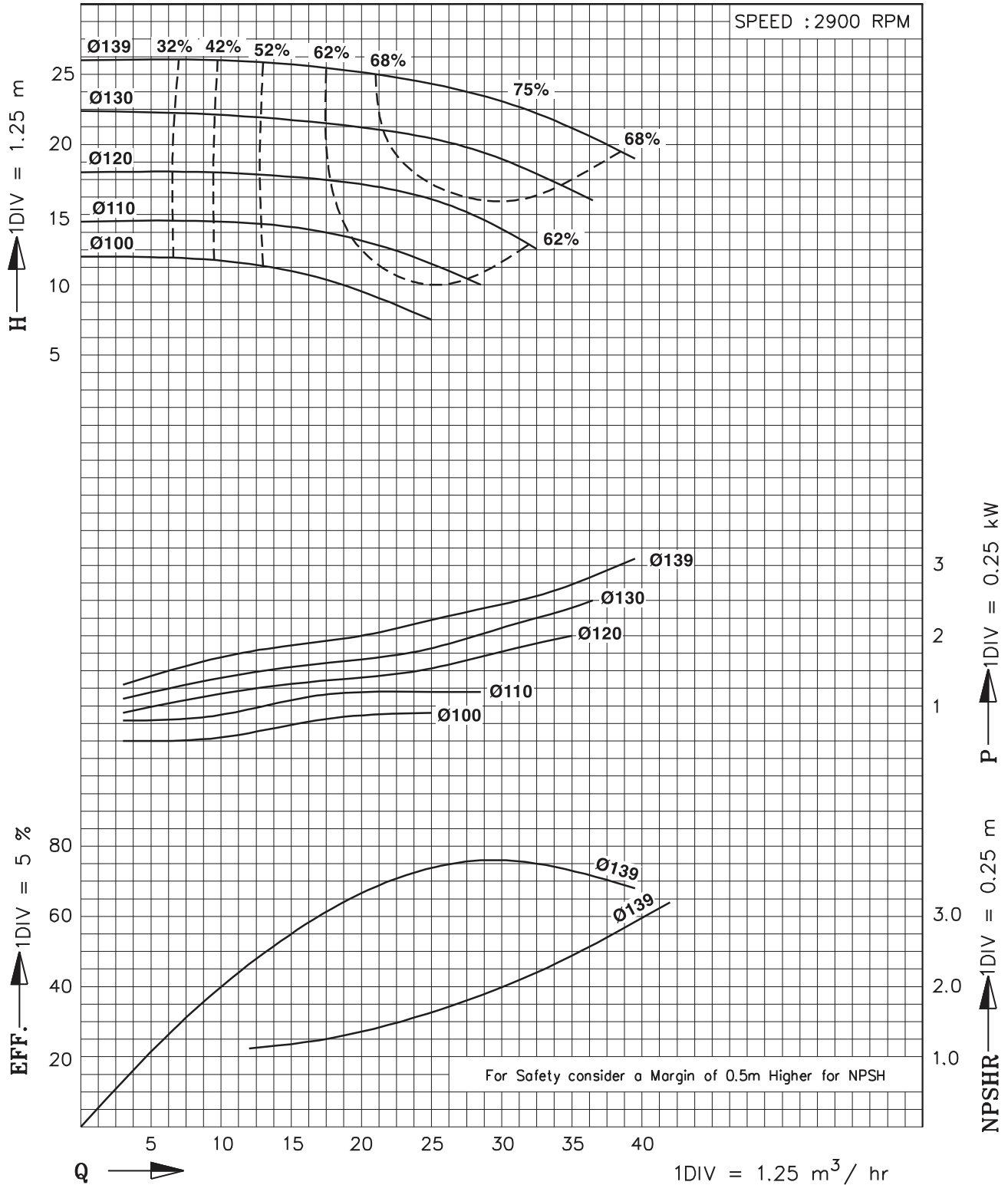



PERFORMANCE CURVE

Model : ECW-40/160

Note : Performance curve are as per specific gravity and viscosity of water.

SIZE : 65 x 40

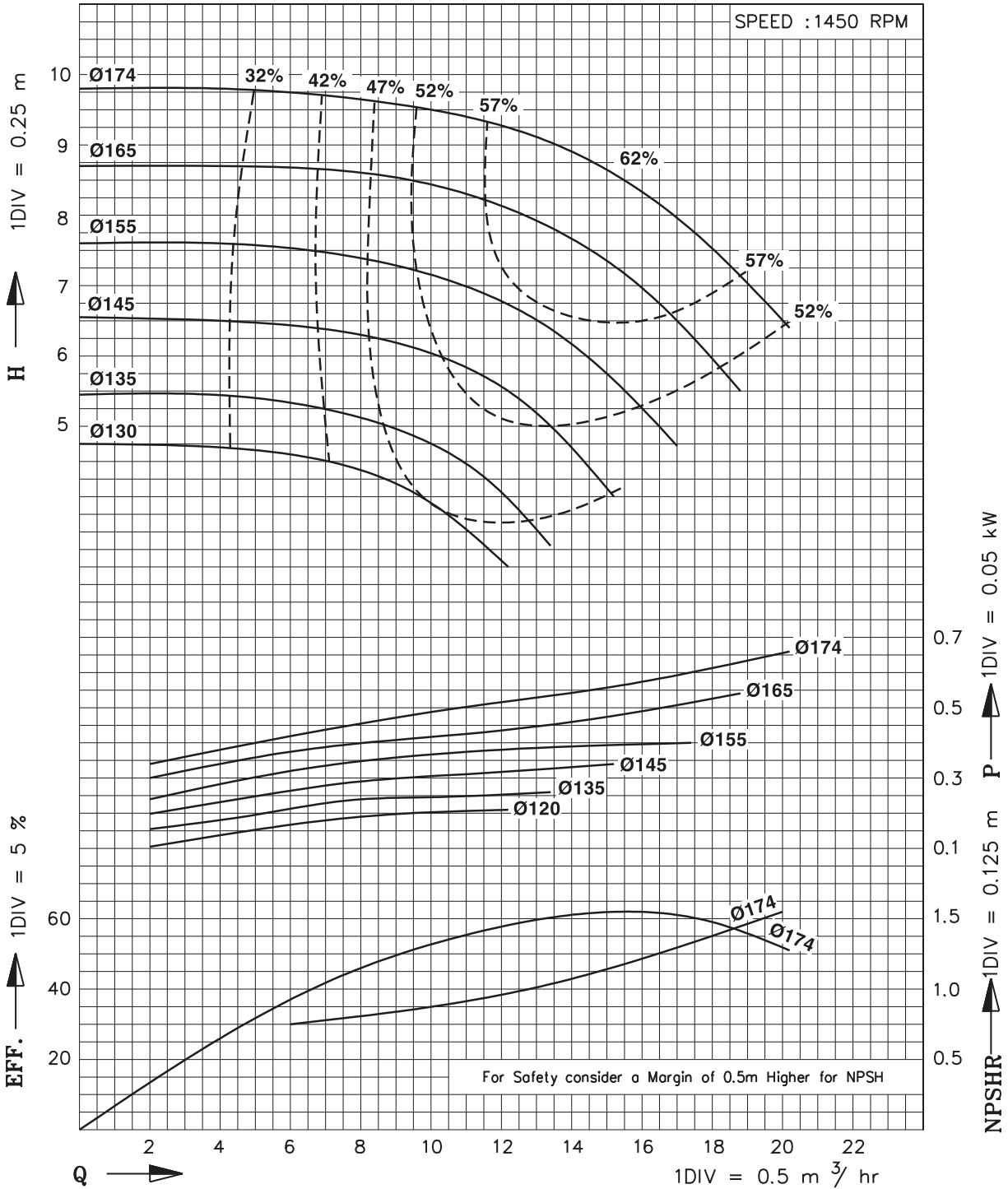

In view of continuous developments the information / performance / descriptions / specifications / Illustrations mentioned in this catalogues are subject to change without notice.



PERFORMANCE CURVE

Model : ECW-40/160

Note : Performance curve are as per specific gravity and viscosity of water.

SIZE : 65 x 40

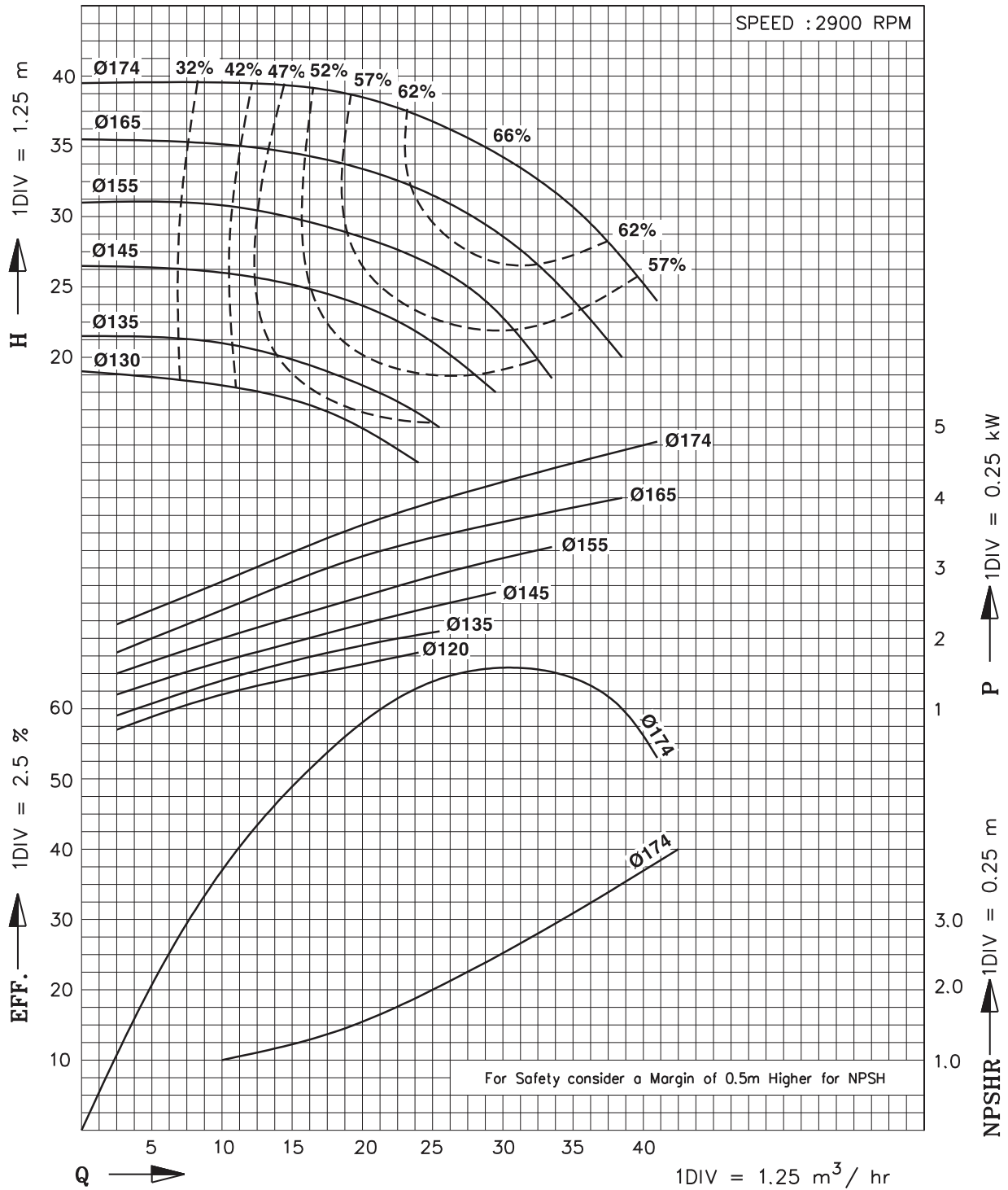



PERFORMANCE CURVE

Model : ECW-40/200

Note : Performance curve are as per specific gravity and viscosity of water.

SIZE : 65 x 40

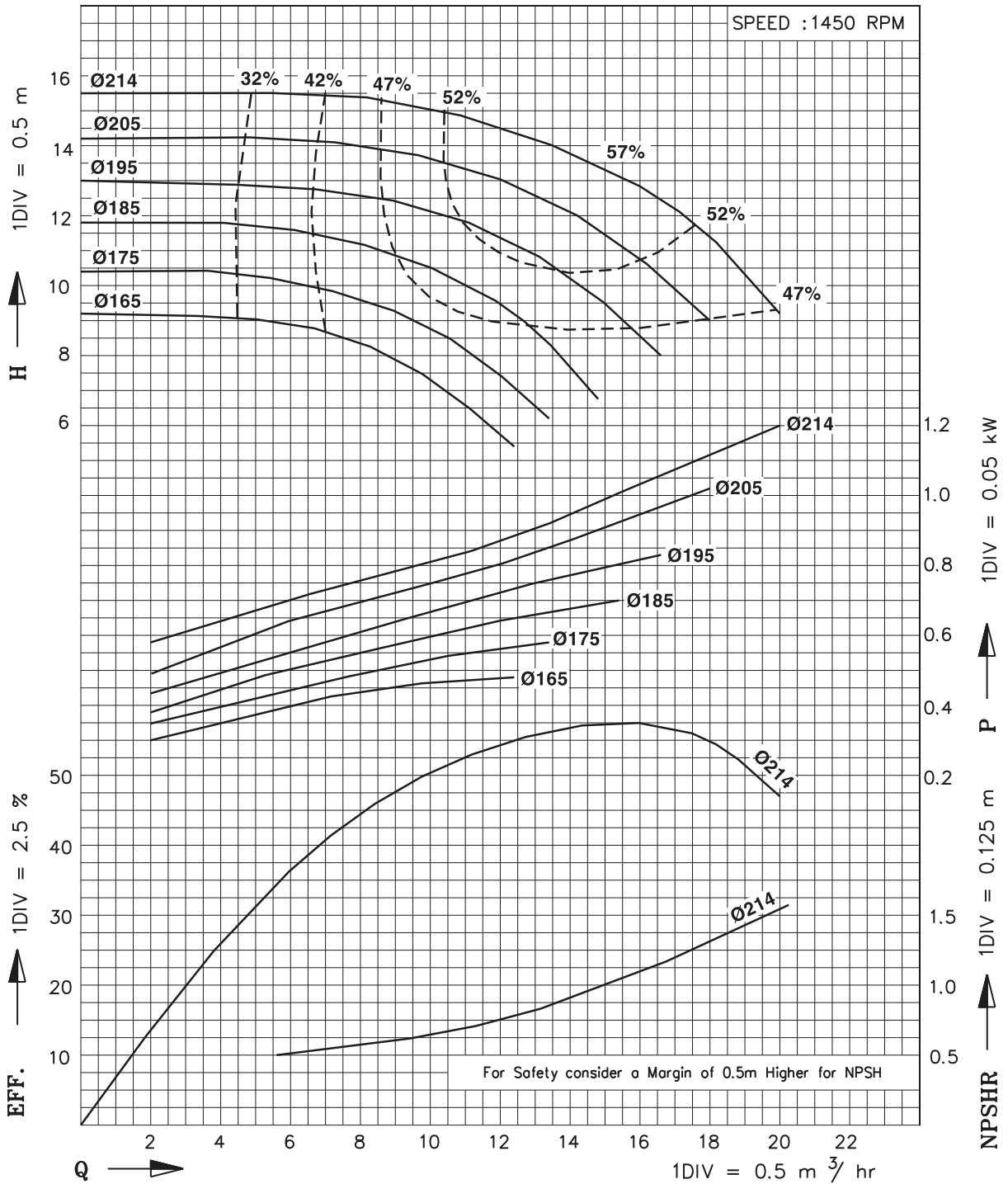



PERFORMANCE CURVE

Model : ECW-40/200

Note : Performance curve are as per specific gravity and viscosity of water.

SIZE : 65 x 40

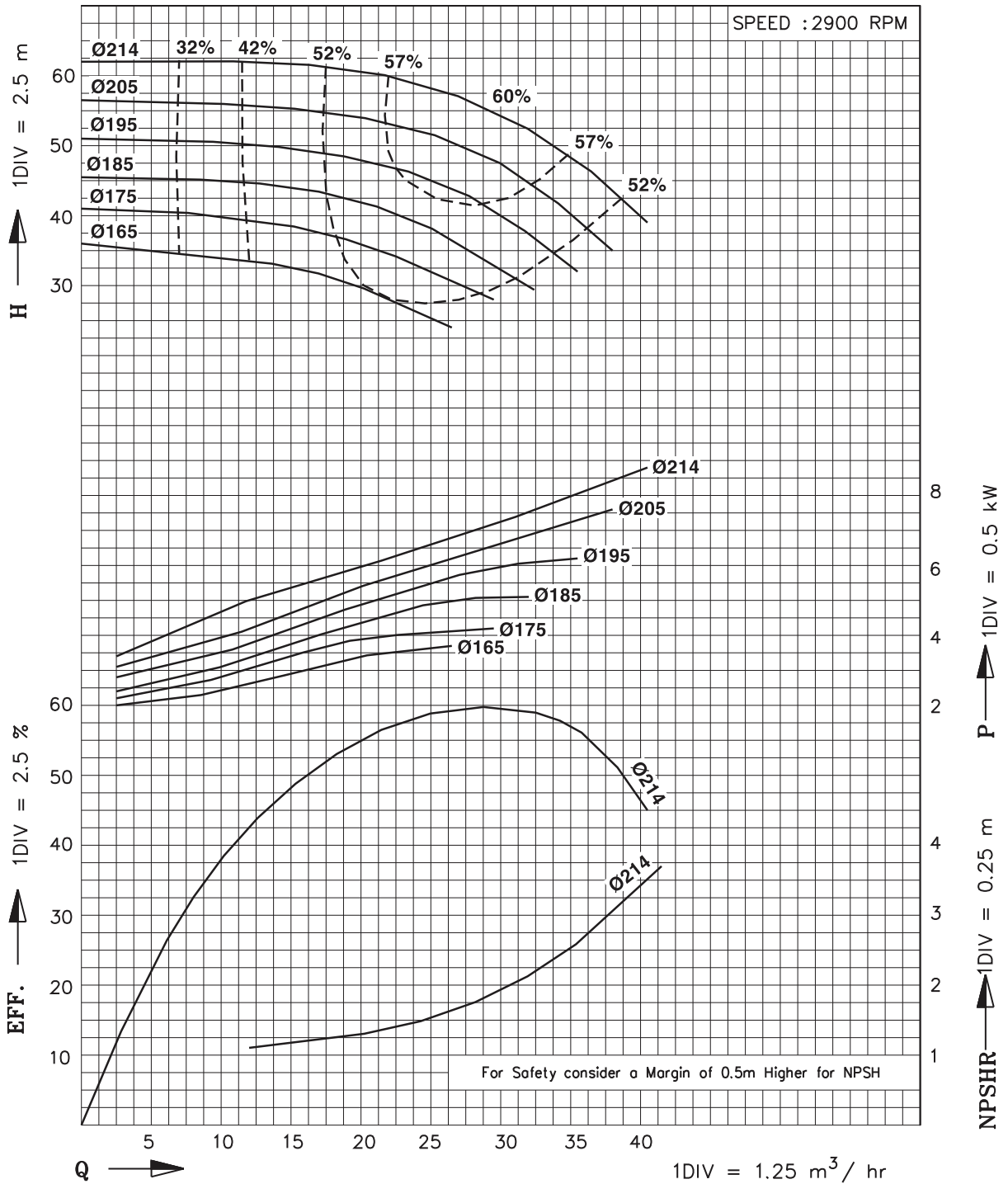



PERFORMANCE CURVE

Model : ECW-40/260

Note : Performance curve are as per specific gravity and viscosity of water.

SIZE : 65 x 40

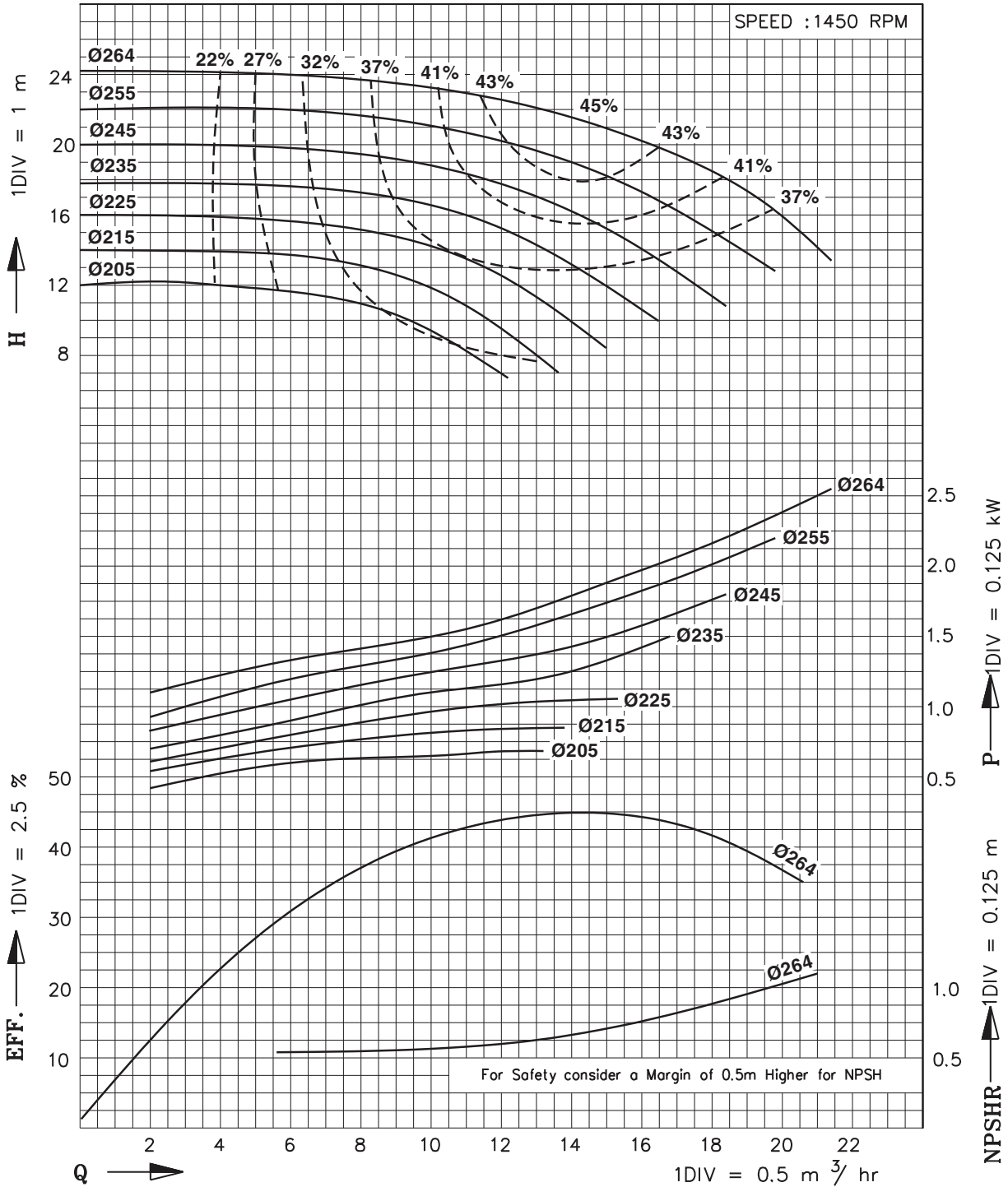

In view of continuous developments the information / performance / descriptions / specifications / Illustrations mentioned in this catalogues are subject to change without notice.



PERFORMANCE CURVE

Model : ECW-40/260

Note : Performance curve are as per specific gravity and viscosity of water.

SIZE : 65 x 40

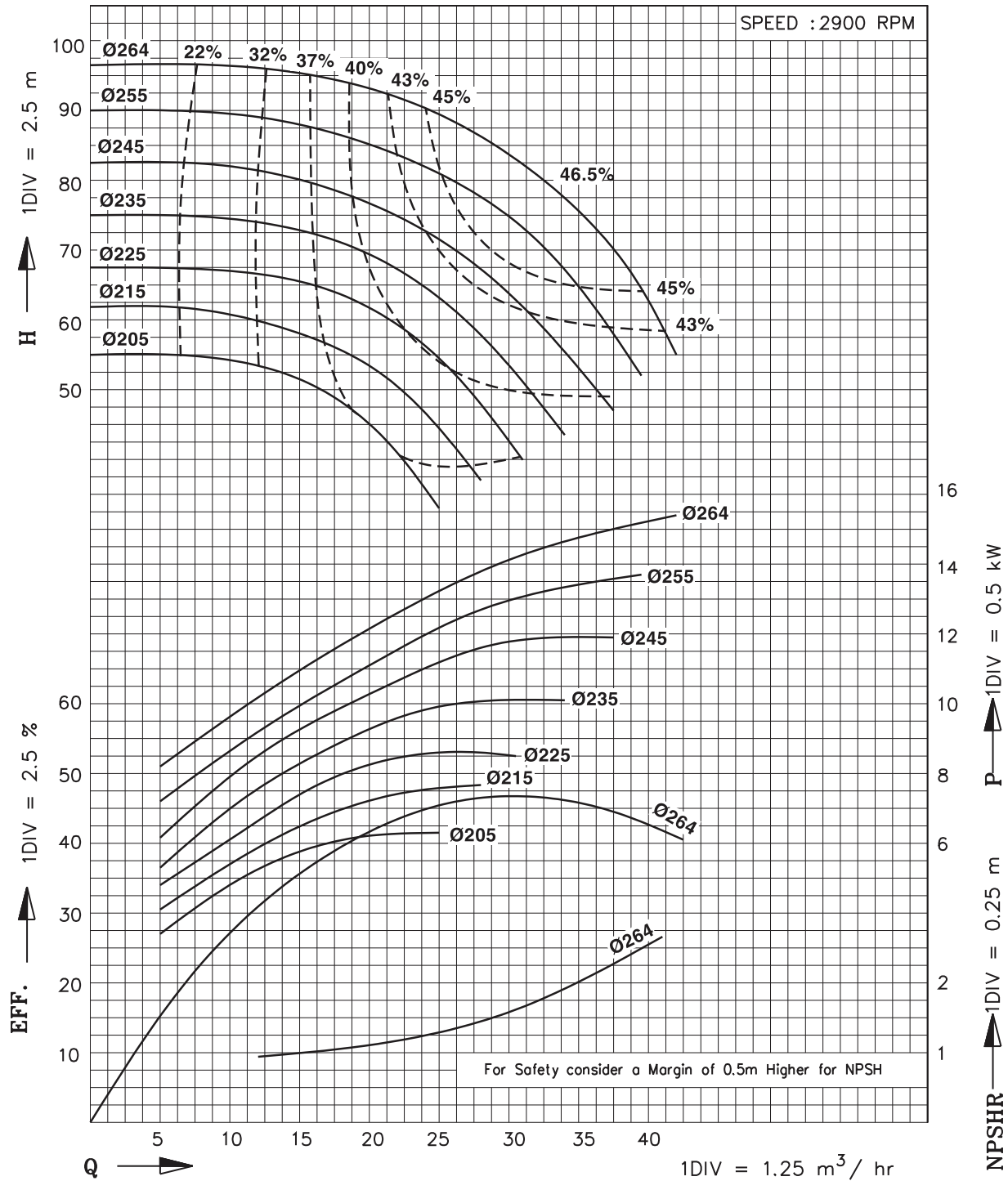



PERFORMANCE CURVE

Model : ECW-40/320

Note : Performance curve are as per specific gravity and viscosity of water.

SIZE : 65 x 40

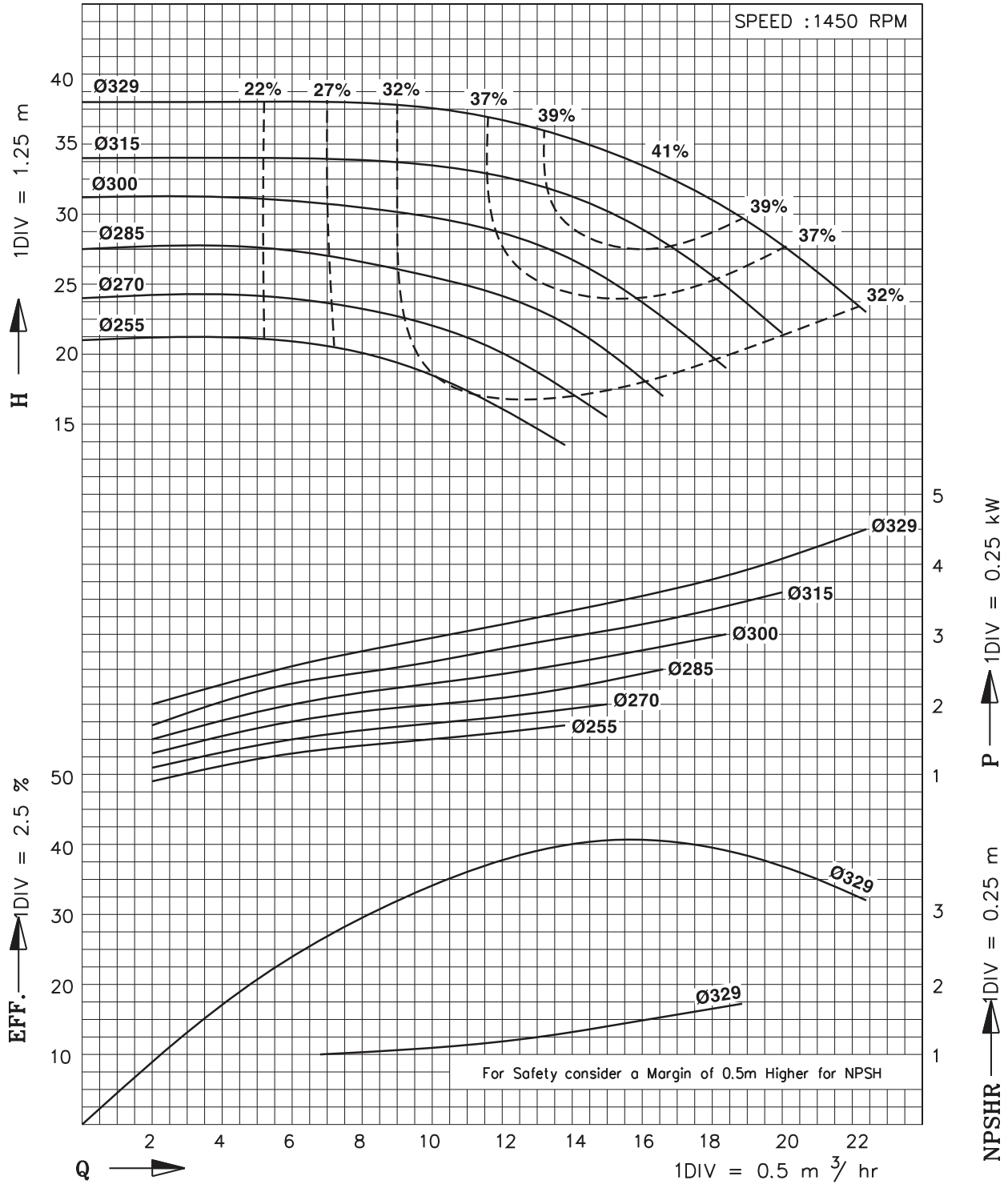

In view of continuous developments the information / performance / descriptions / specifications / Illustrations mentioned in this catalogues are subject to change without notice.



PERFORMANCE CURVE

Model : ECW-40/320-On request

Note : Performance curve are as per specific gravity and viscosity of water.

SIZE : 65 x 40

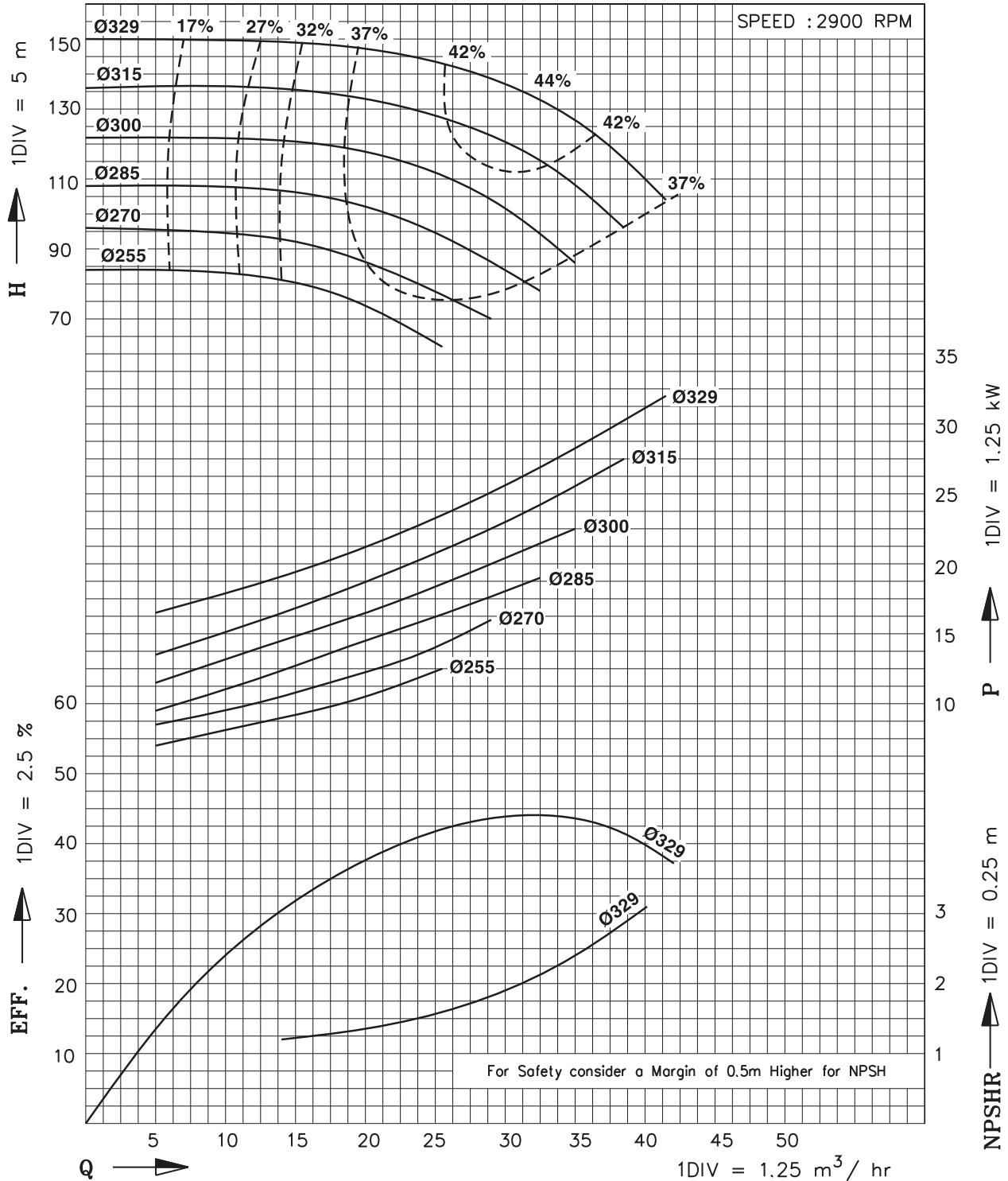



PERFORMANCE CURVE

Model : ECW-50/130

Note : Performance curve are as per specific gravity and viscosity of water.

SIZE : 65 x 50

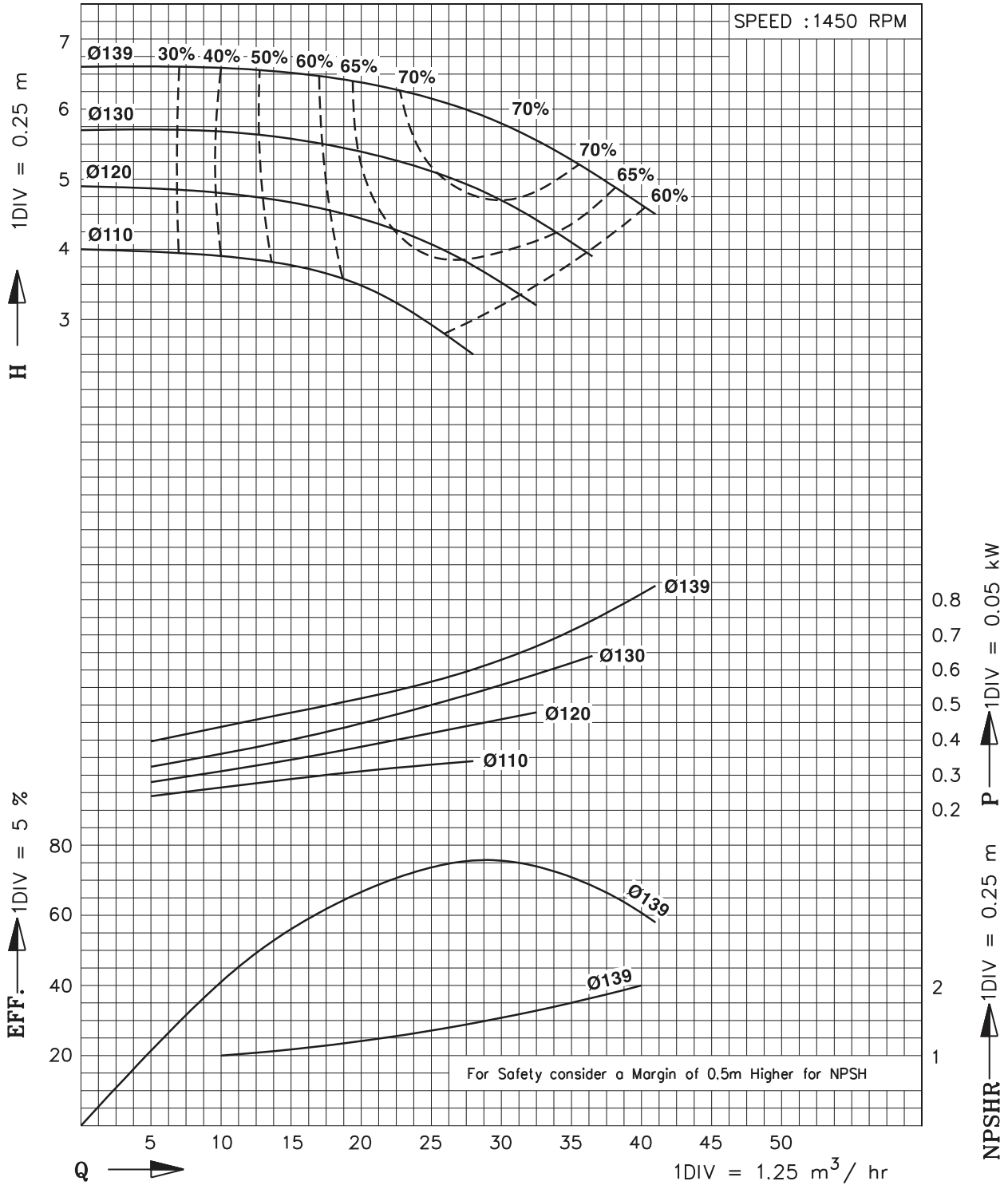

In view of continuous developments the information / performance / descriptions / specifications / Illustrations mentioned in this catalogues are subject to change without notice.



PERFORMANCE CURVE

Model : ECW-50/130

Note : Performance curve are as per specific gravity and viscosity of water.

SIZE : 65 x 50

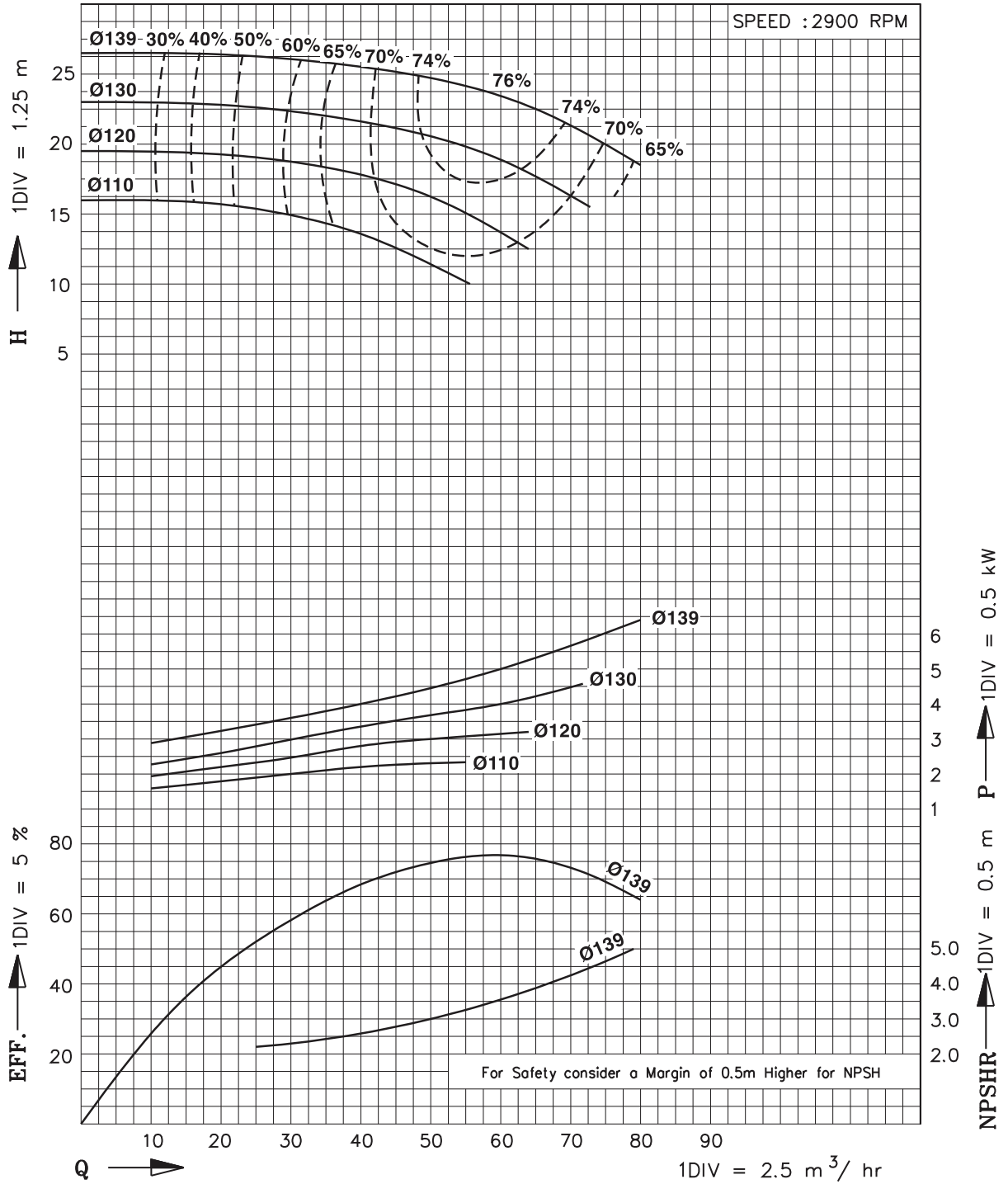



PERFORMANCE CURVE

Model : ECW-50/160

Note : Performance curve are as per specific gravity and viscosity of water.

SIZE : 65 x 50

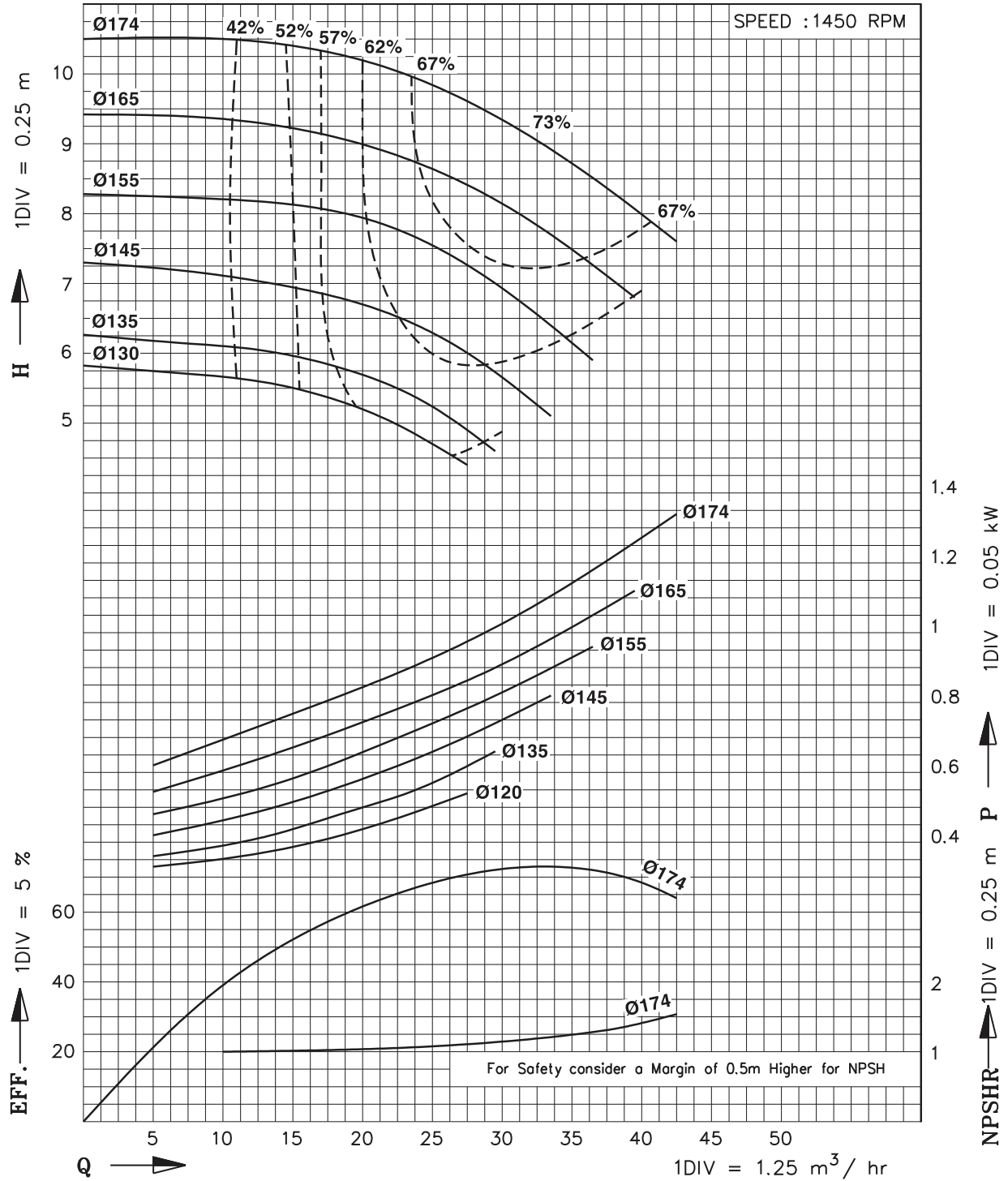



PERFORMANCE CURVE

Model : ECW-50/160

Note : Performance curve are as per specific gravity and viscosity of water.

SIZE : 65 x 50

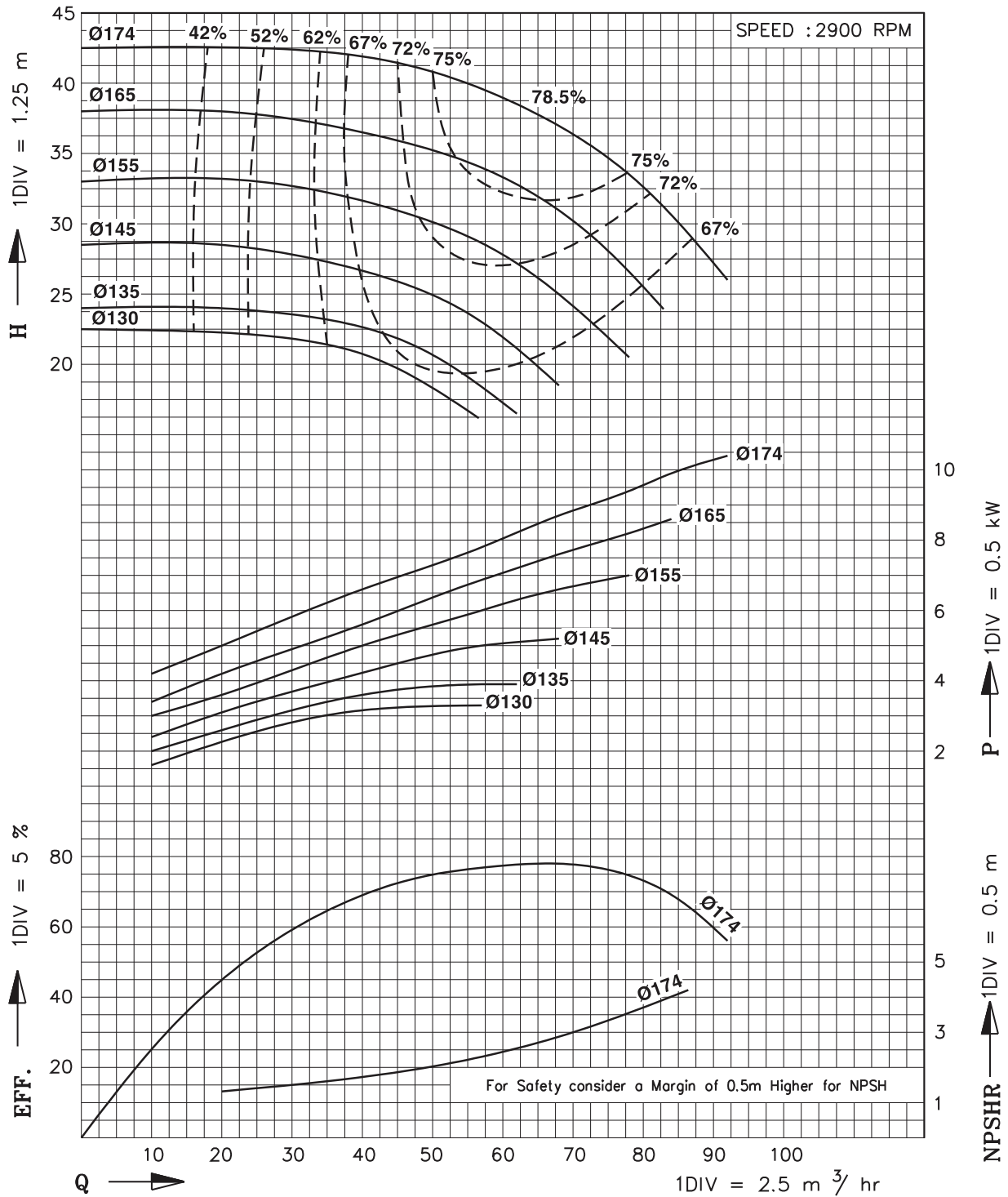



PERFORMANCE CURVE

Model : ECW-50/200

Note : Performance curve are as per specific gravity and viscosity of water.

SIZE : 65 x 50

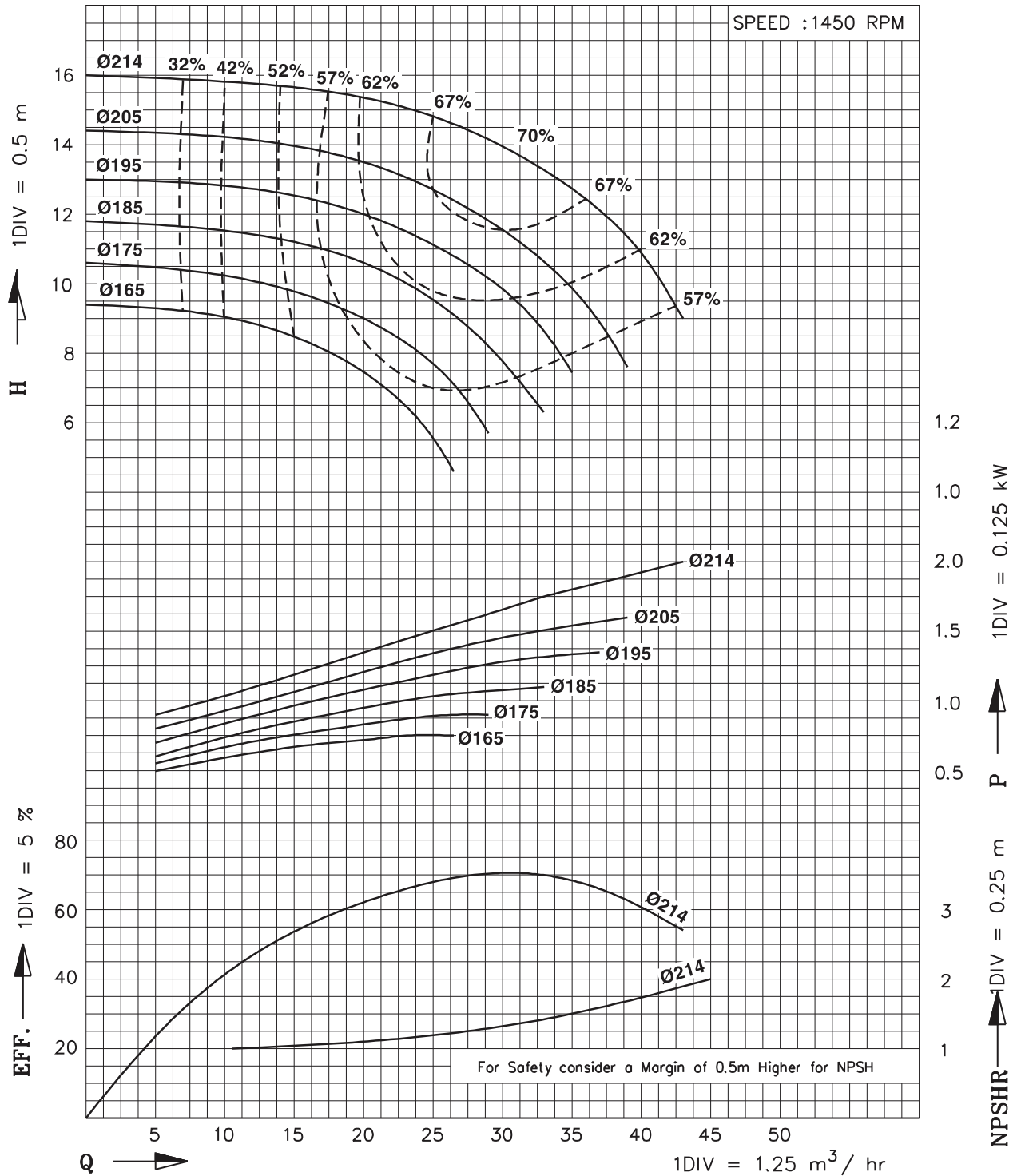

In view of continuous developments the information / performance / descriptions / specifications / Illustrations mentioned in this catalogues are subject to change without notice.



PERFORMANCE CURVE

Model : ECW-50/200

Note : Performance curve are as per specific gravity and viscosity of water.

SIZE : 65 x 50

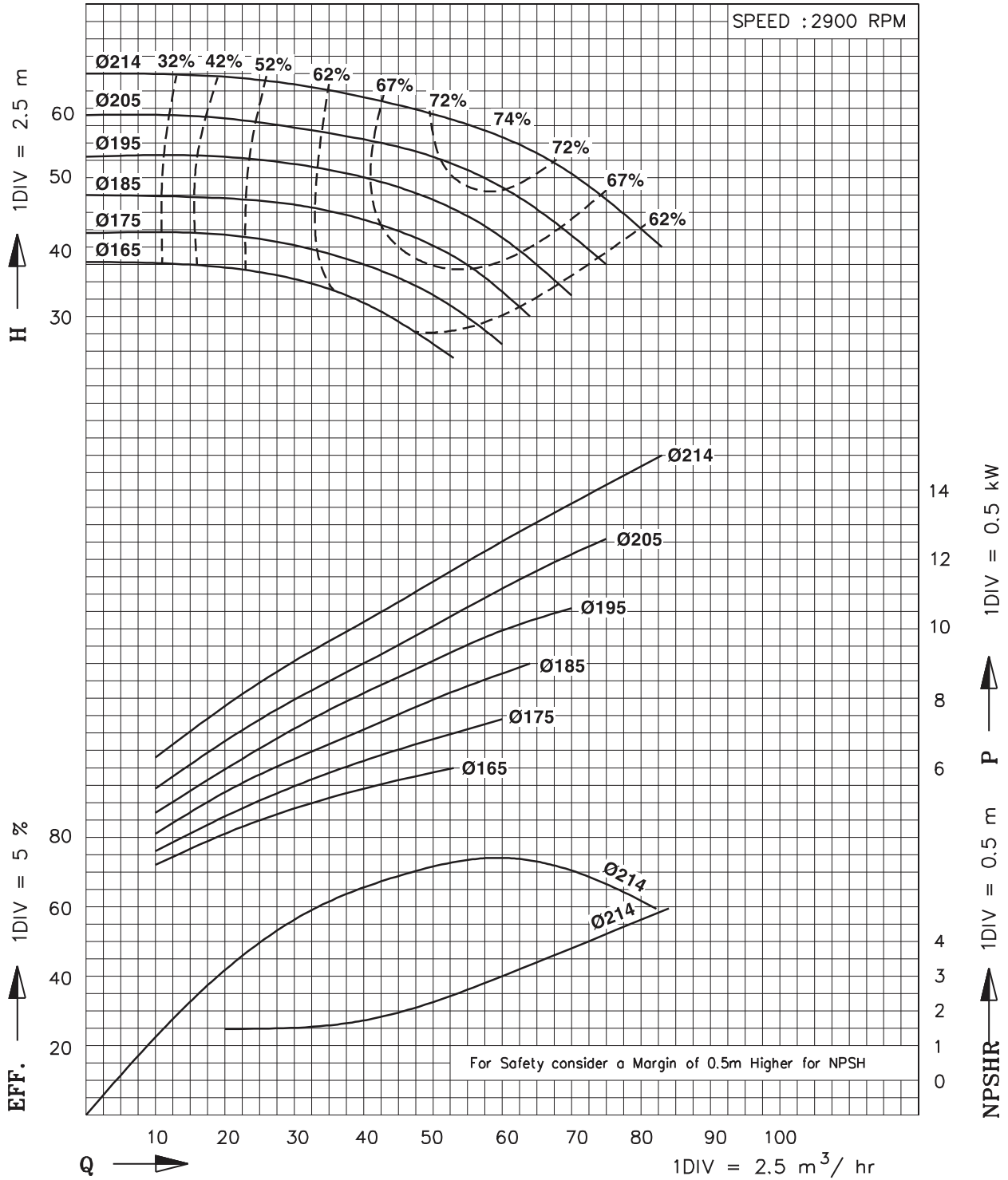



PERFORMANCE CURVE

Model : ECW-50/260

Note : Performance curve are as per specific gravity and viscosity of water.

SIZE : 65 x 50

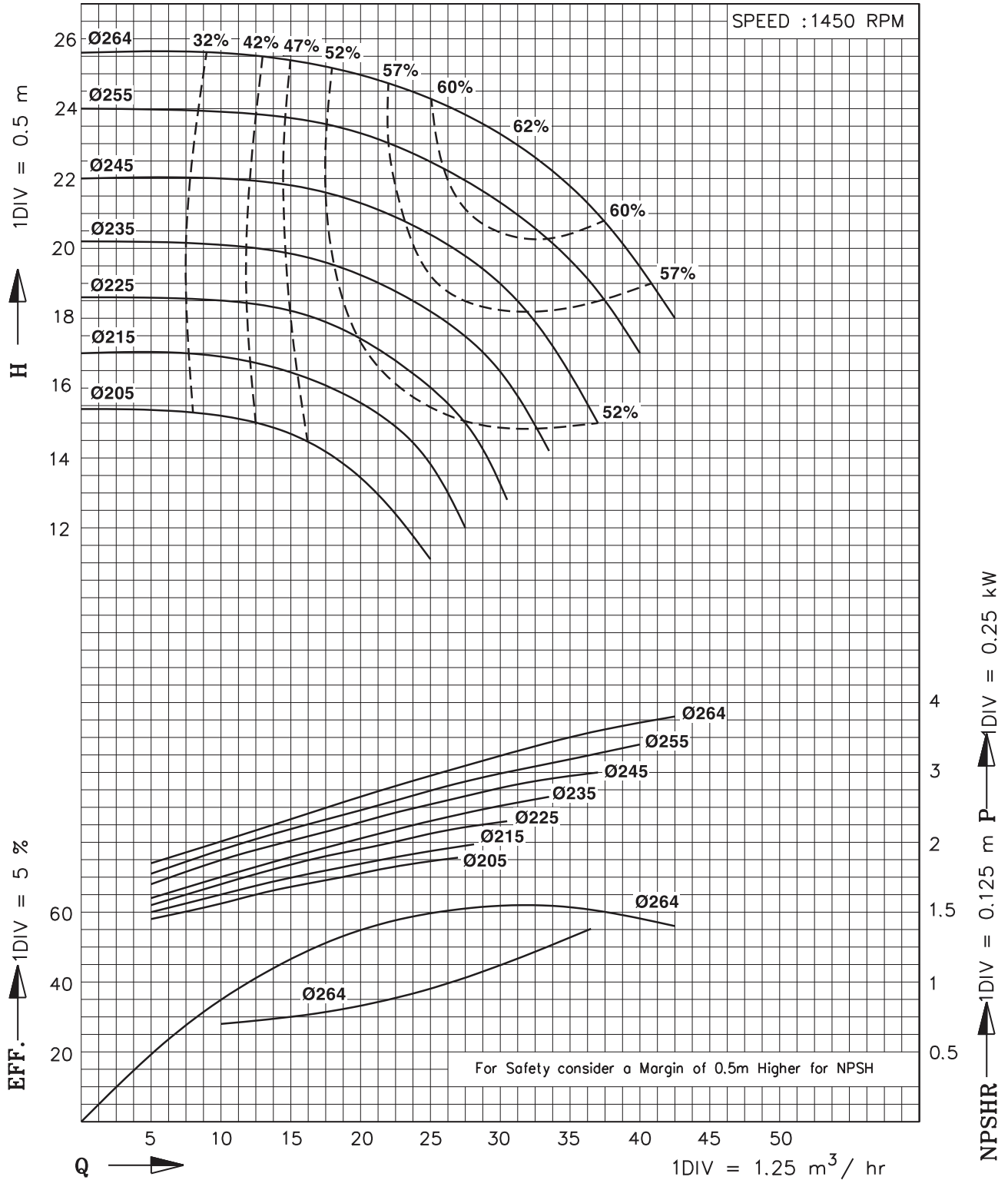

In view of continuous developments the information / performance / descriptions / specifications / Illustrations mentioned in this catalogues are subject to change without notice.



PERFORMANCE CURVE

Model : ECW-50/260

Note : Performance curve are as per specific gravity and viscosity of water.

SIZE : 65 x 50

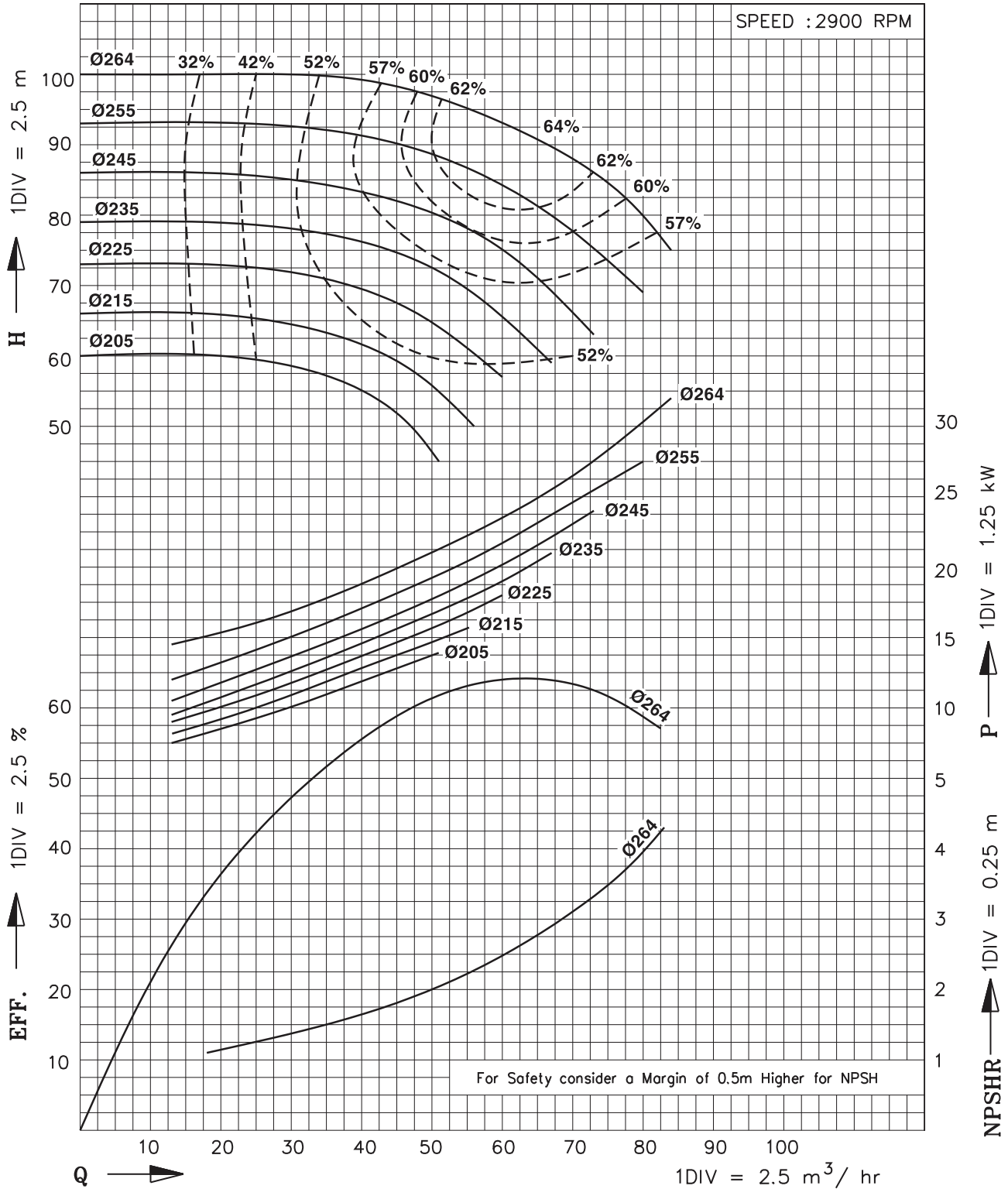



PERFORMANCE CURVE

Model : ECW-50/320

Note : Performance curve are as per specific gravity and viscosity of water.

SIZE : 80 x 50

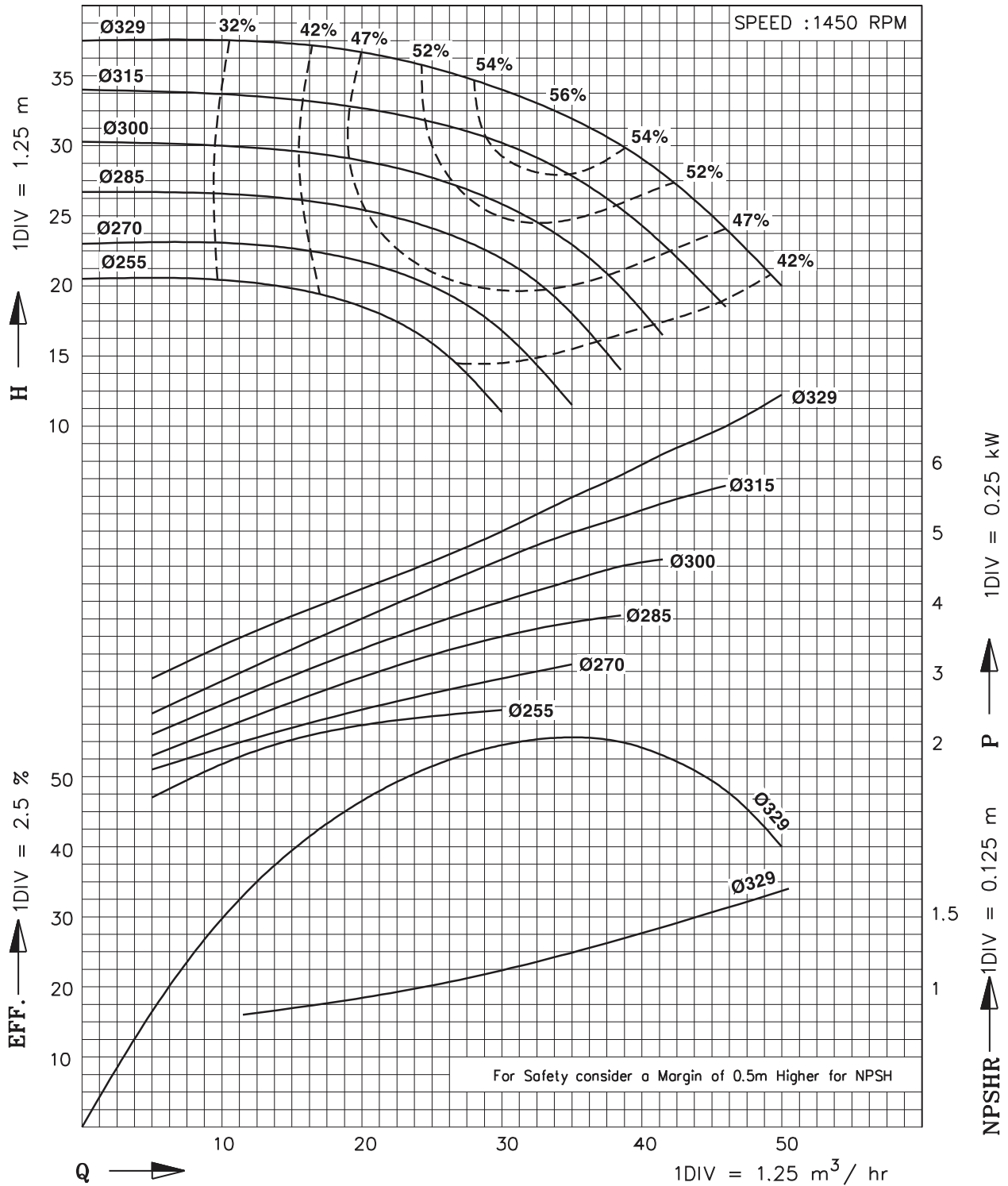



PERFORMANCE CURVE

Model : ECW-50/320-On request

Note : Performance curve are as per specific gravity and viscosity of water.

SIZE : 80 x 50

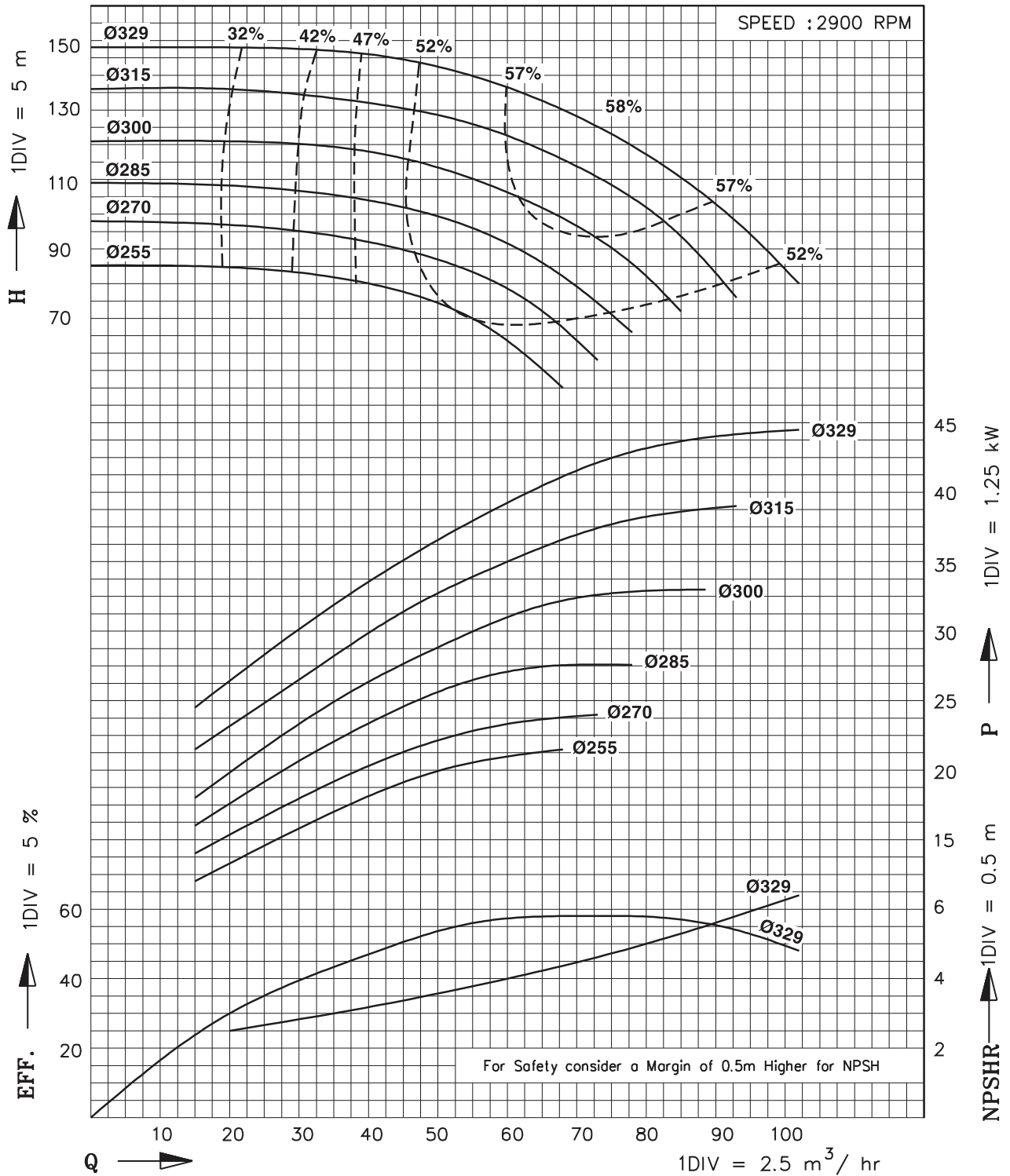



PERFORMANCE CURVE

Model : ECW-65/130

Note : Performance curve are as per specific gravity and viscosity of water.

SIZE : 80 x 65

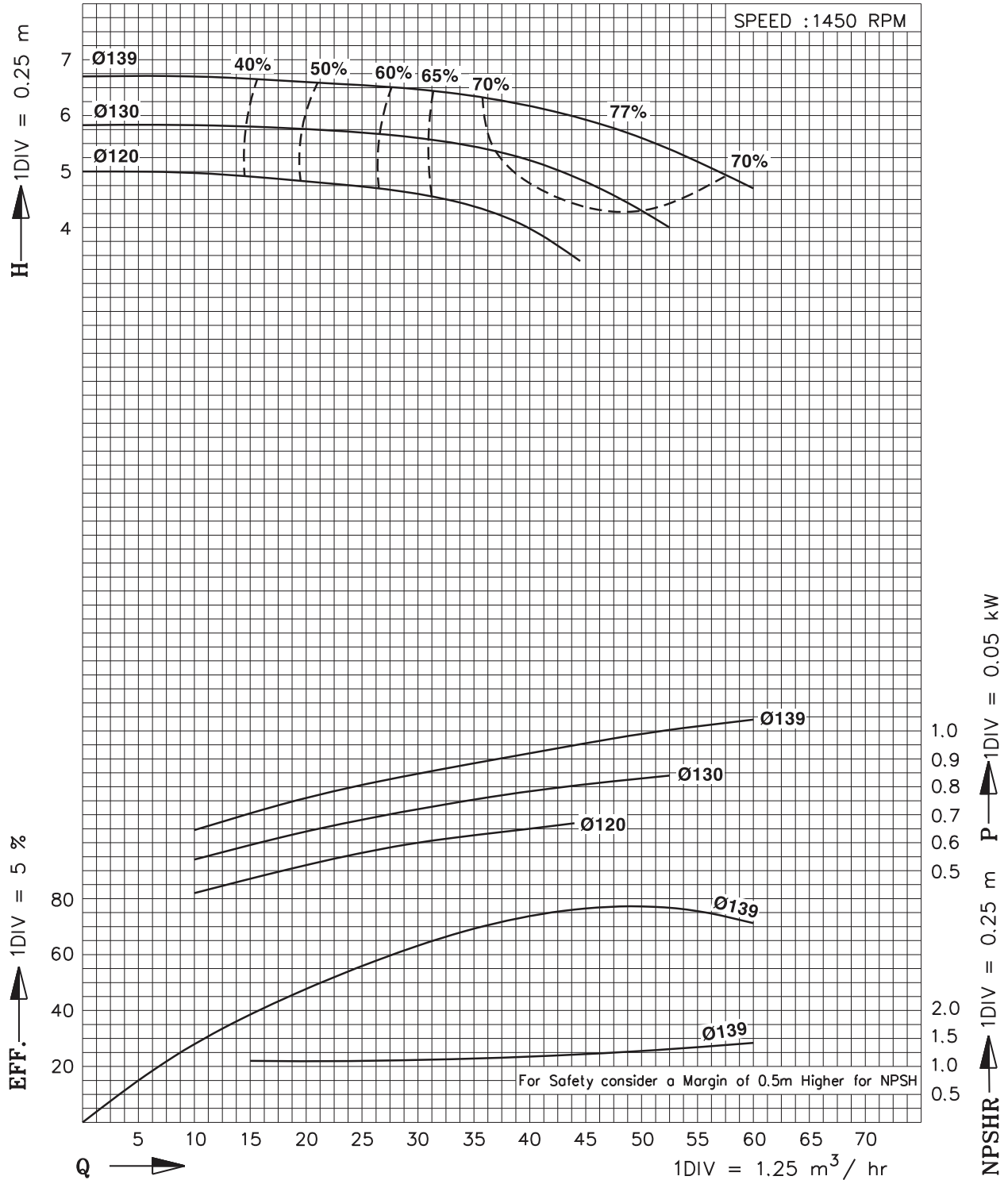



PERFORMANCE CURVE

Model : ECW-65/130

Note : Performance curve are as per specific gravity and viscosity of water.

SIZE : 80 x 65

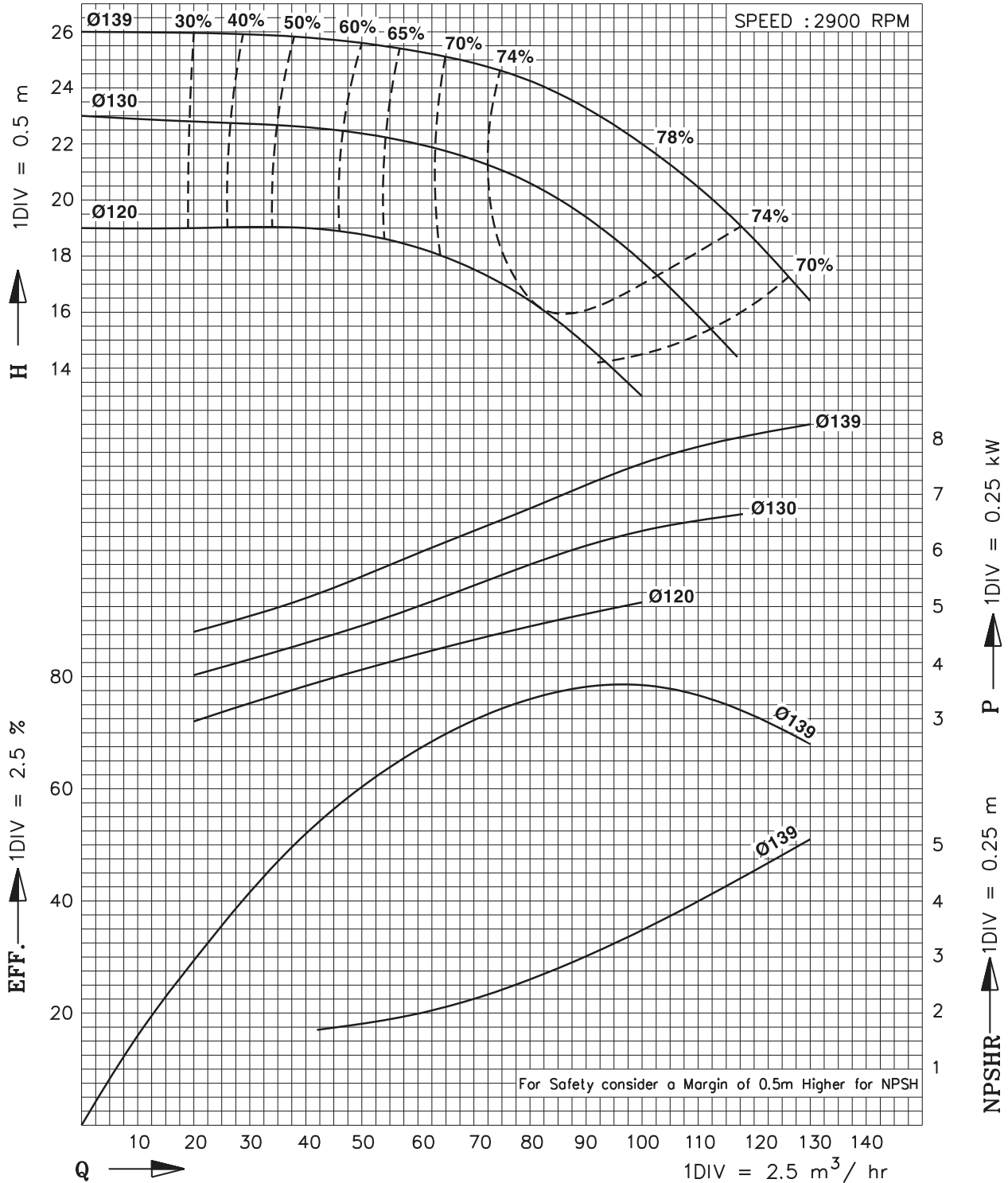



PERFORMANCE CURVE

Model : ECW-65/160

Note : Performance curve are as per specific gravity and viscosity of water.

SIZE : 80 x 65

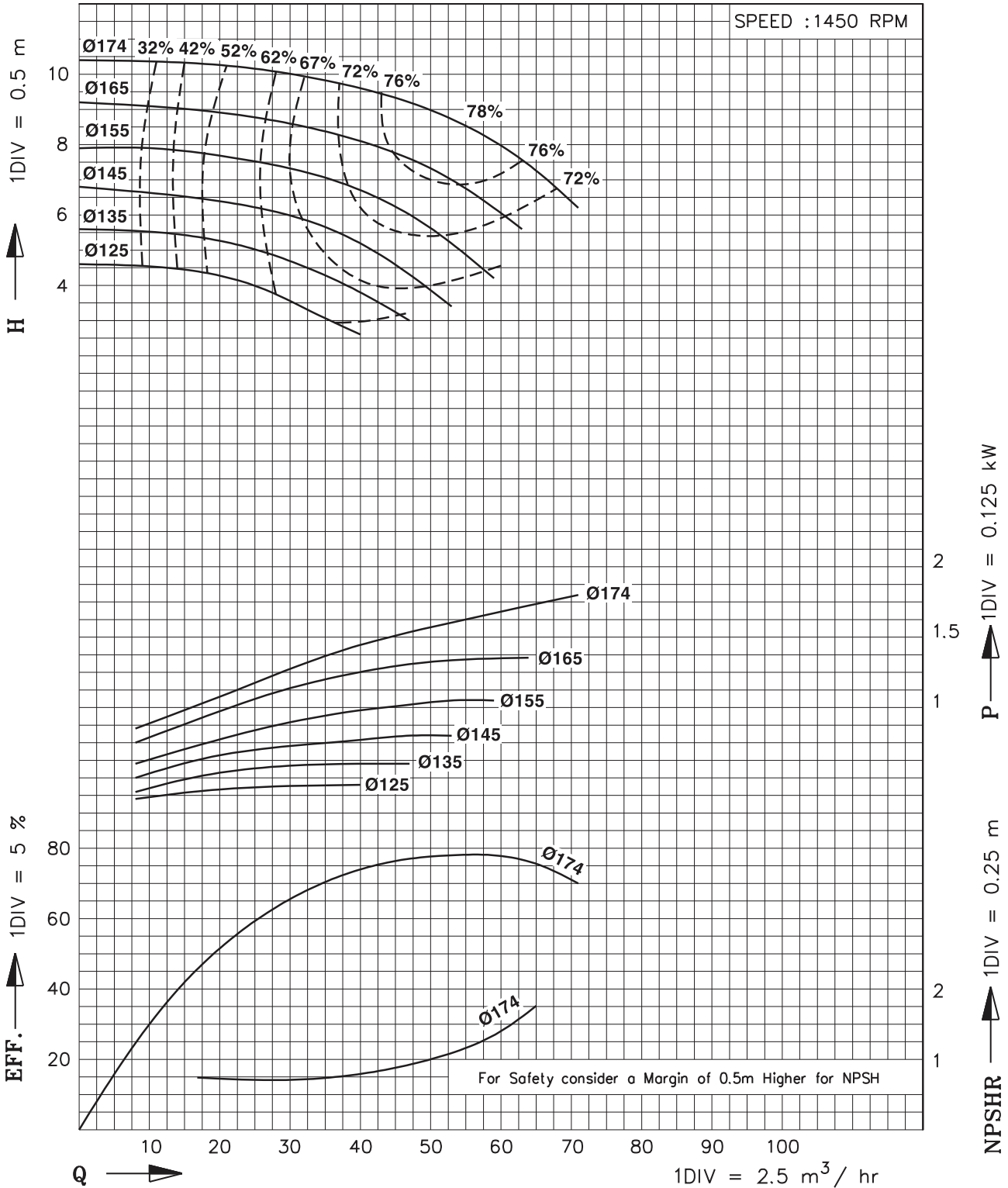



PERFORMANCE CURVE

Model : ECW-65/160

Note : Performance curve are as per specific gravity and viscosity of water.

SIZE : 80 x 65

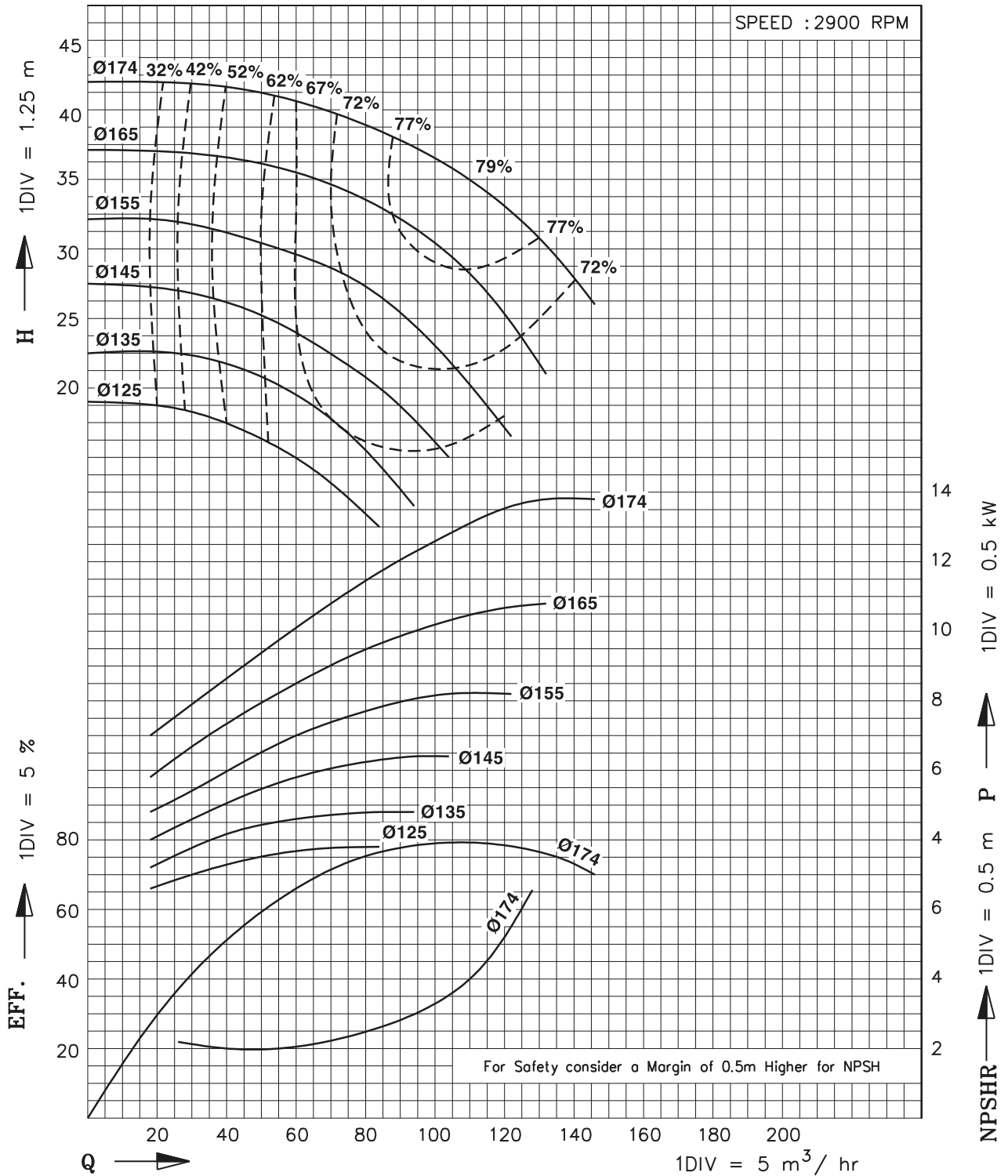



PERFORMANCE CURVE

Model : ECW-65/200

Note : Performance curve are as per specific gravity and viscosity of water.

SIZE : 80 x 65

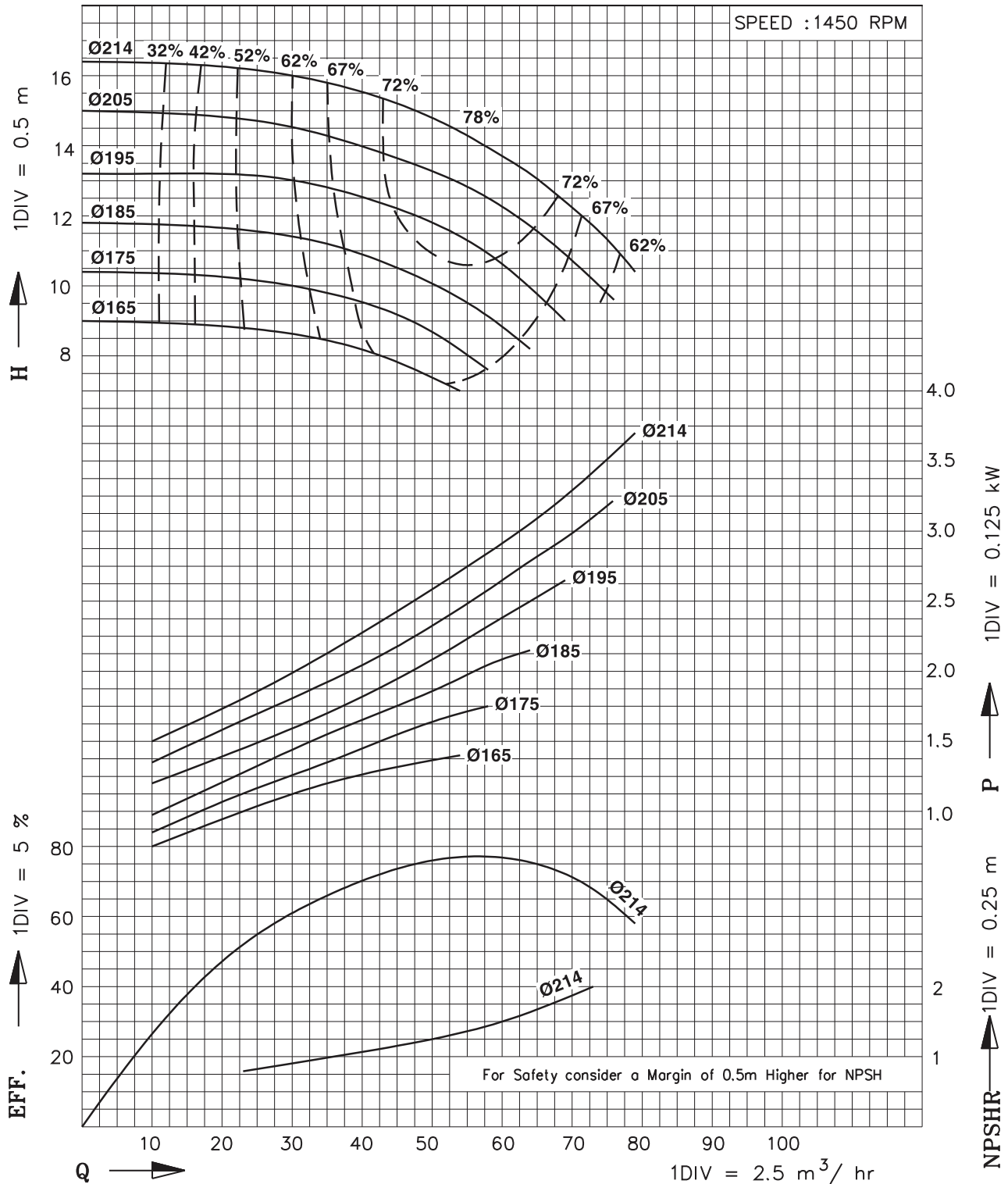

In view of continuous developments the information / performance / descriptions / specifications / Illustrations mentioned in this catalogues are subject to change without notice.



PERFORMANCE CURVE

Model : ECW-65/200

Note : Performance curve are as per specific gravity and viscosity of water.

SIZE : 80 x 65

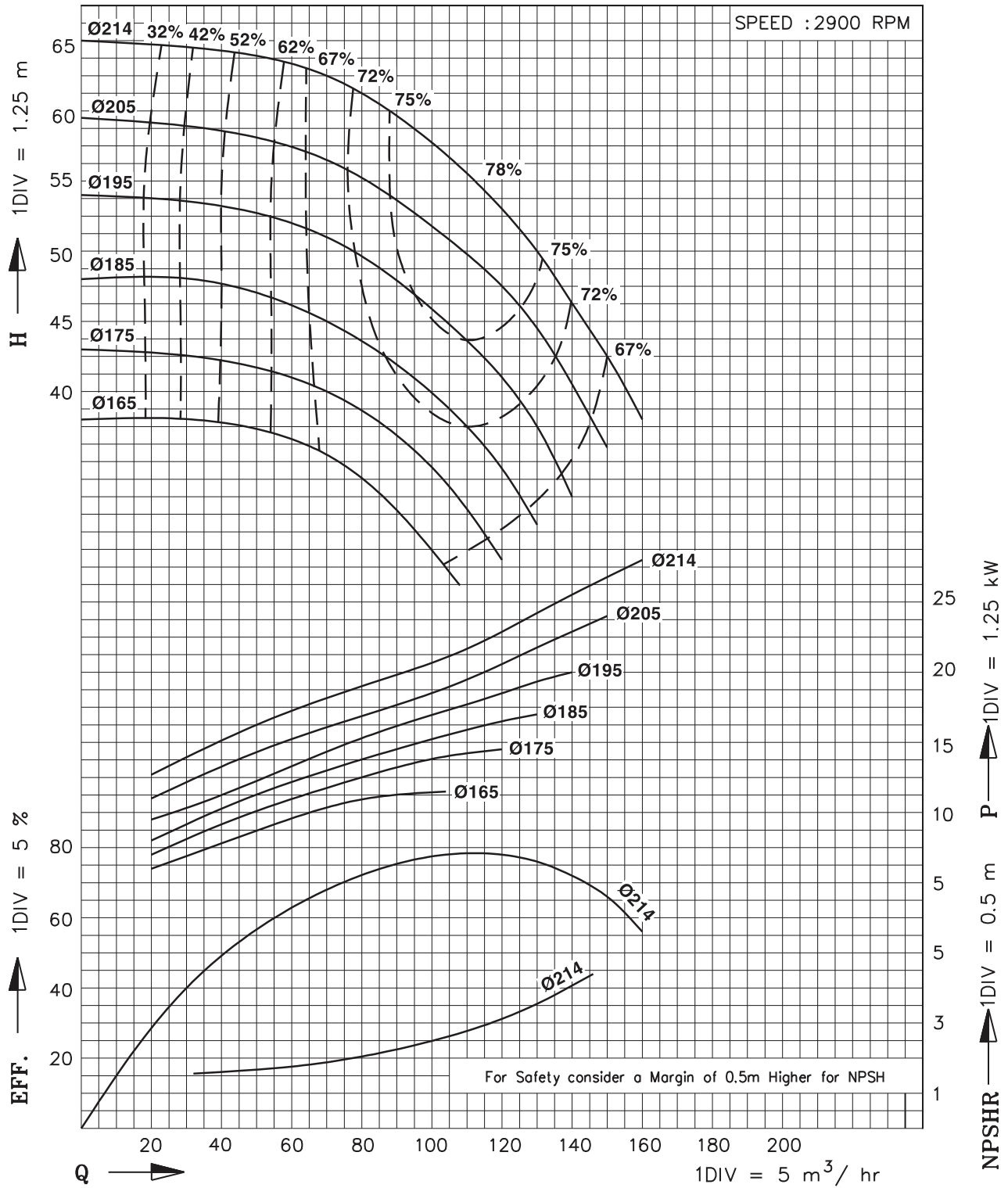



PERFORMANCE CURVE

Model : ECW-65/260

Note : Performance curve are as per specific gravity and viscosity of water.

SIZE : 80 x 65

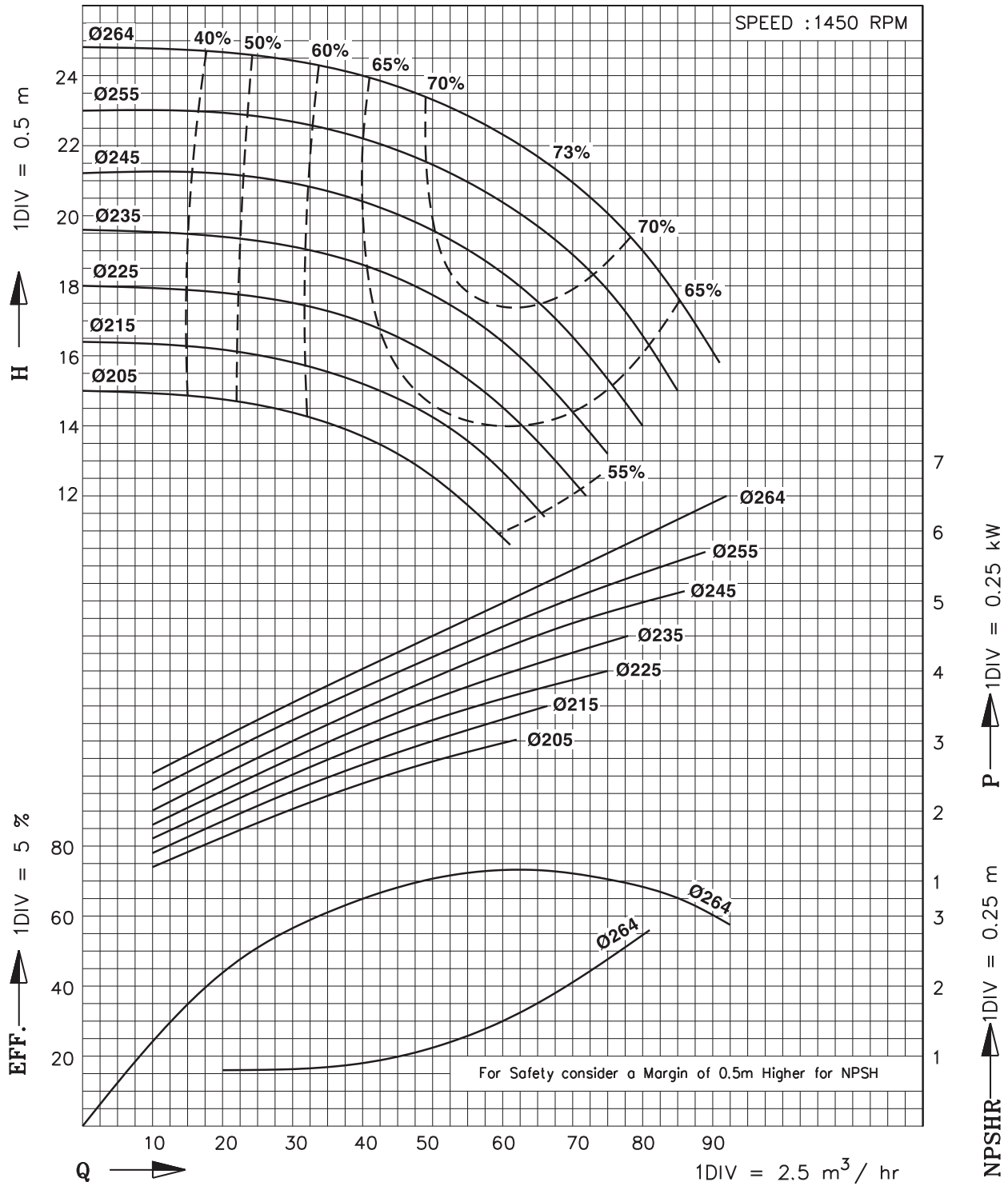

In view of continuous developments the information / performance / descriptions / specifications / Illustrations mentioned in this catalogues are subject to change without notice.



PERFORMANCE CURVE

Model : ECW-65/260

Note : Performance curve are as per specific gravity and viscosity of water.

SIZE : 80 x 65

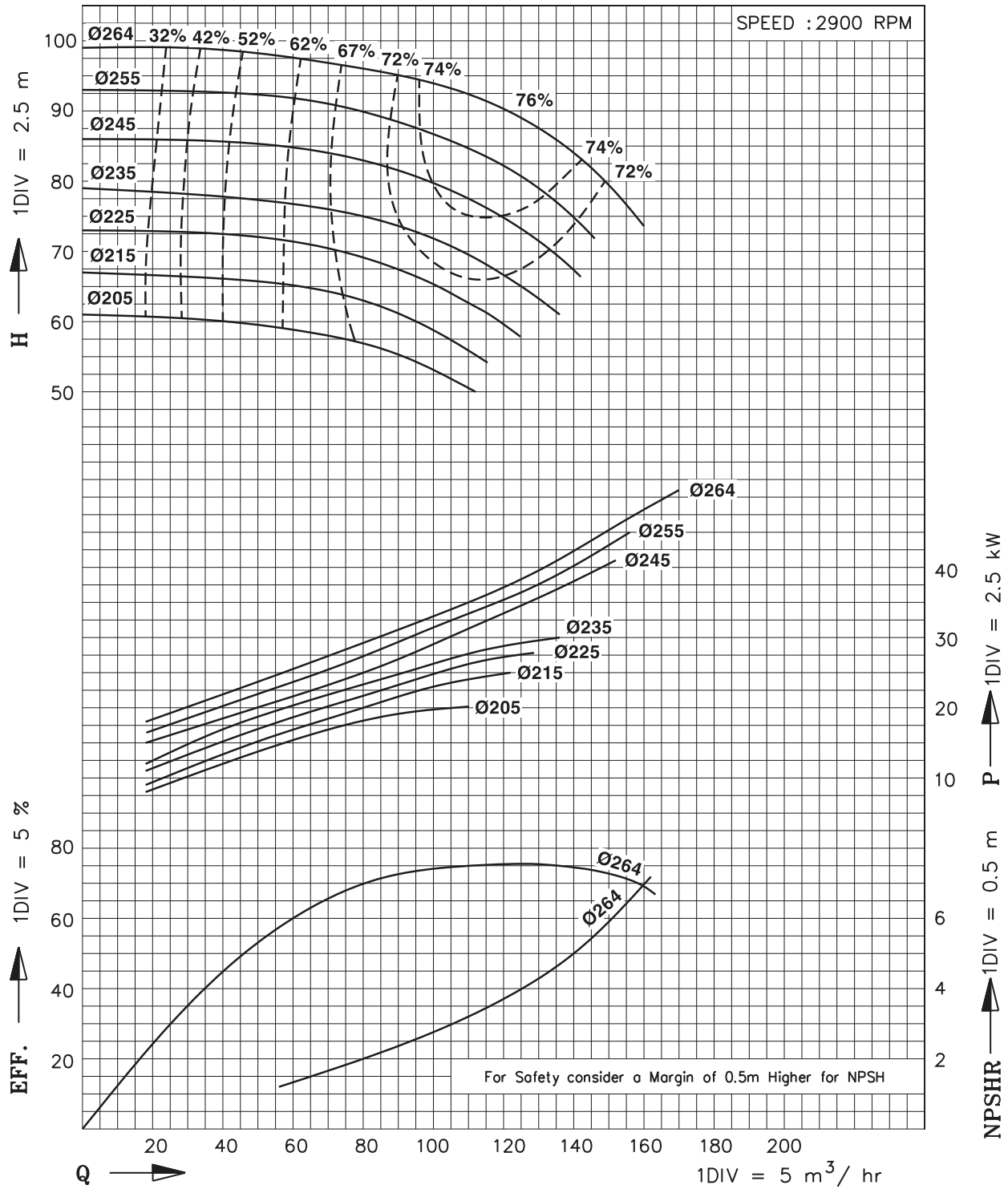



PERFORMANCE CURVE

Model : ECW-65/320

Note : Performance curve are as per specific gravity and viscosity of water.

SIZE : 80 x 65

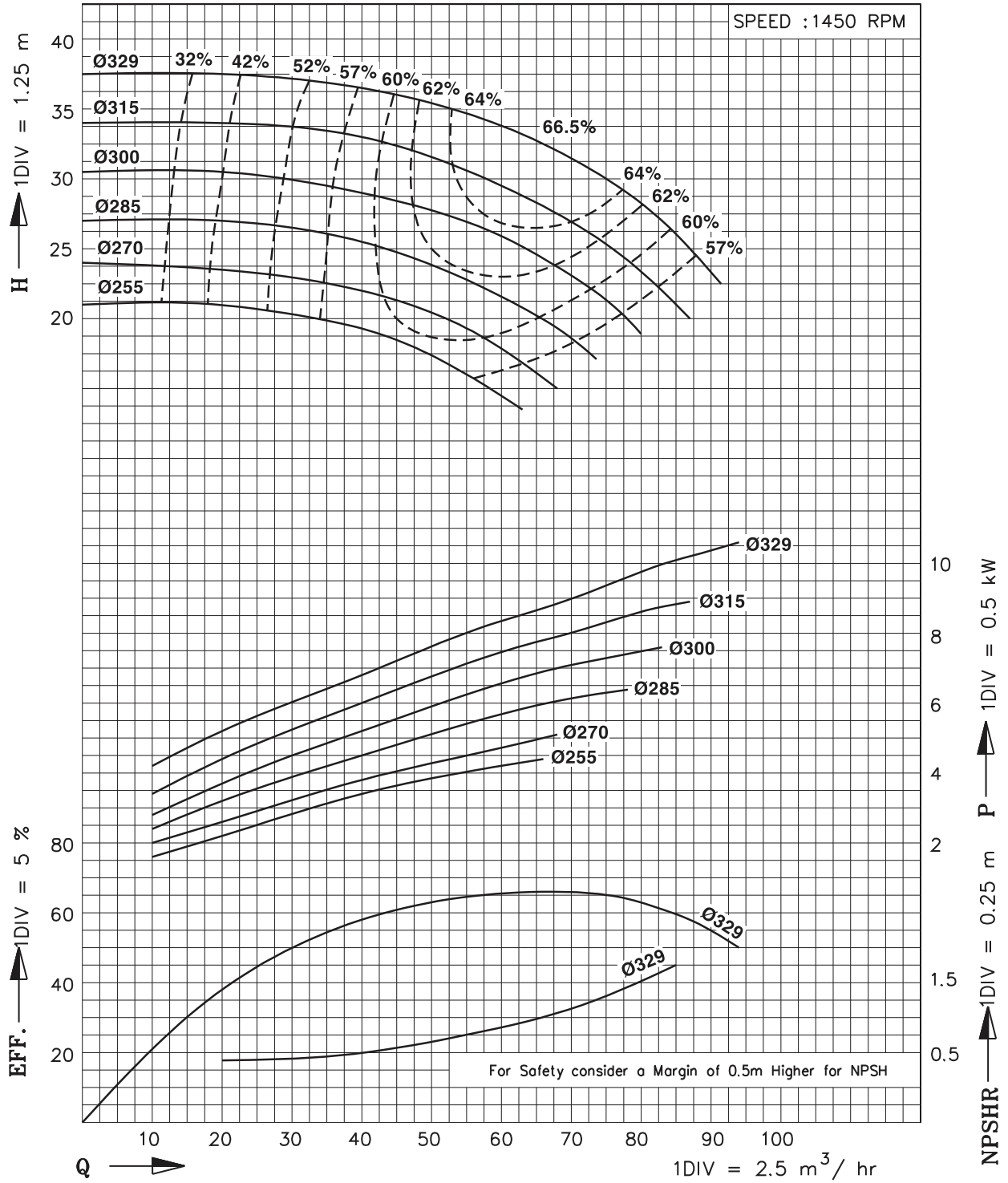

In view of continuous developments the information / performance / descriptions / specifications / Illustrations mentioned in this catalogues are subject to change without notice.



PERFORMANCE CURVE

Model : ECW-65/320-On request

Note : Performance curve are as per specific gravity and viscosity of water.

SIZE : 80 x 65

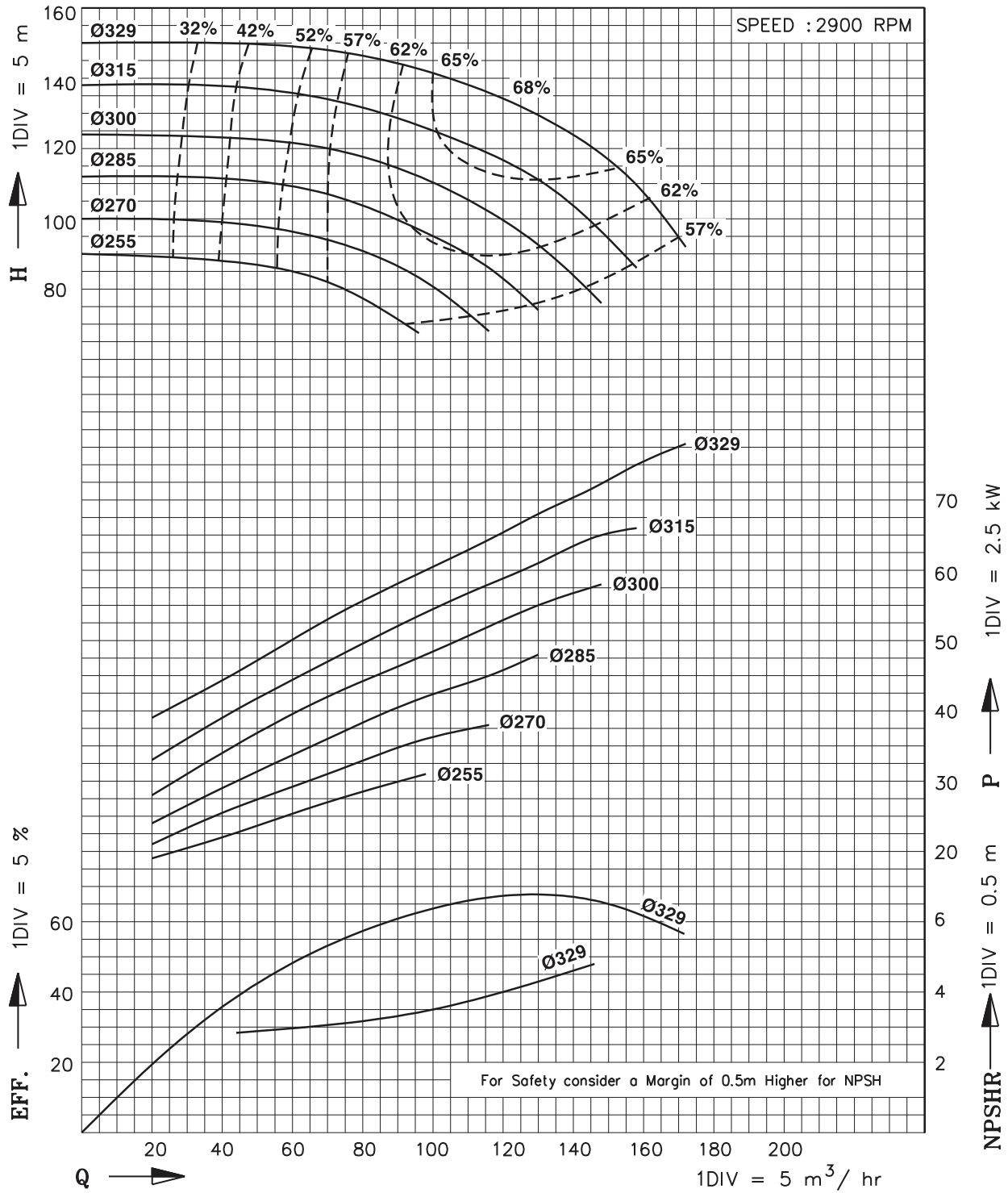



PERFORMANCE CURVE

Model : ECW-80/160

Note : Performance curve are as per specific gravity and viscosity of water.

SIZE : 100 x 80

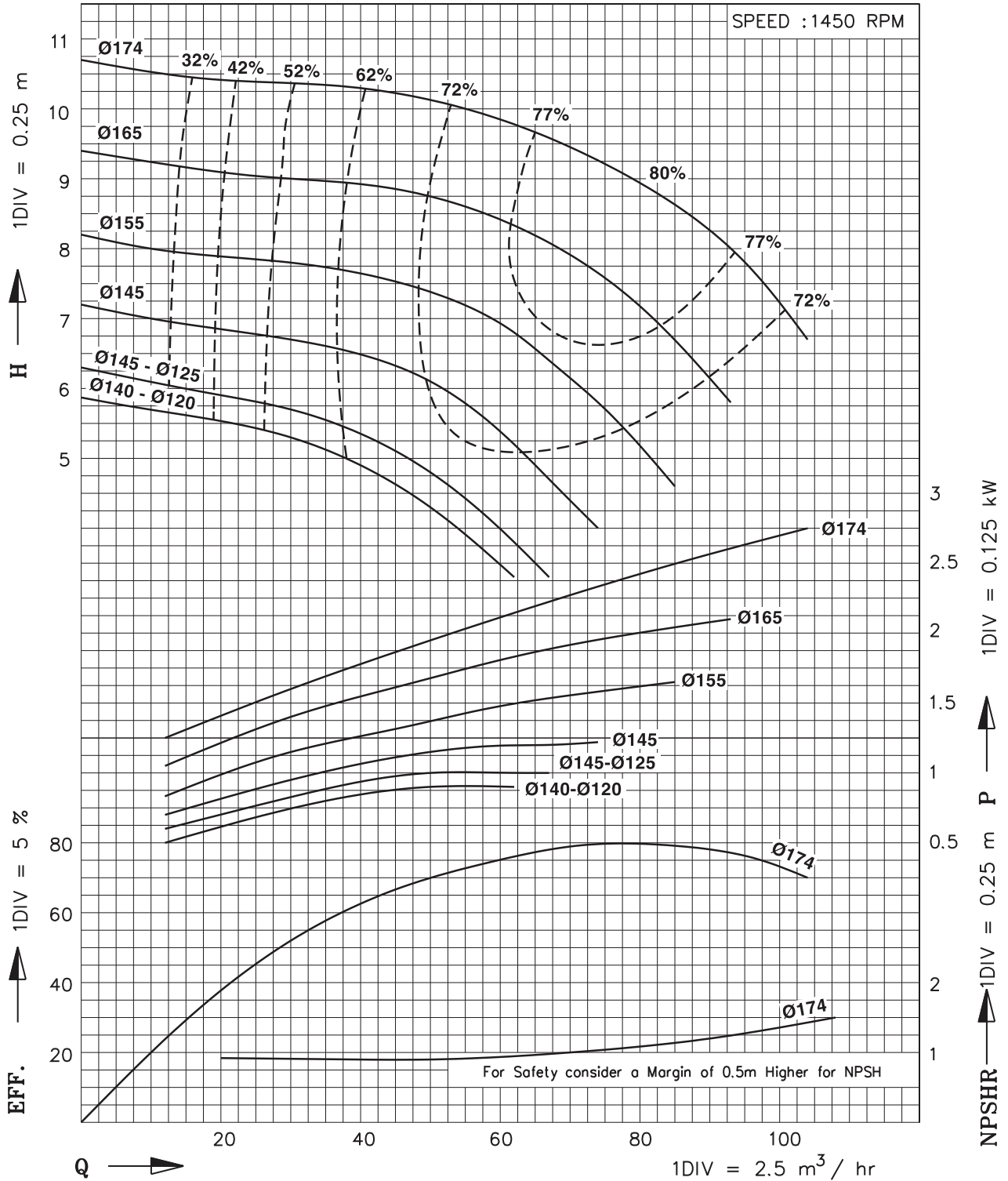

In view of continuous developments the information / performance / descriptions / specifications / Illustrations mentioned in this catalogues are subject to change without notice.



PERFORMANCE CURVE

Model : ECW-80/160

Note : Performance curve are as per specific gravity and viscosity of water.

SIZE : 100 x 80

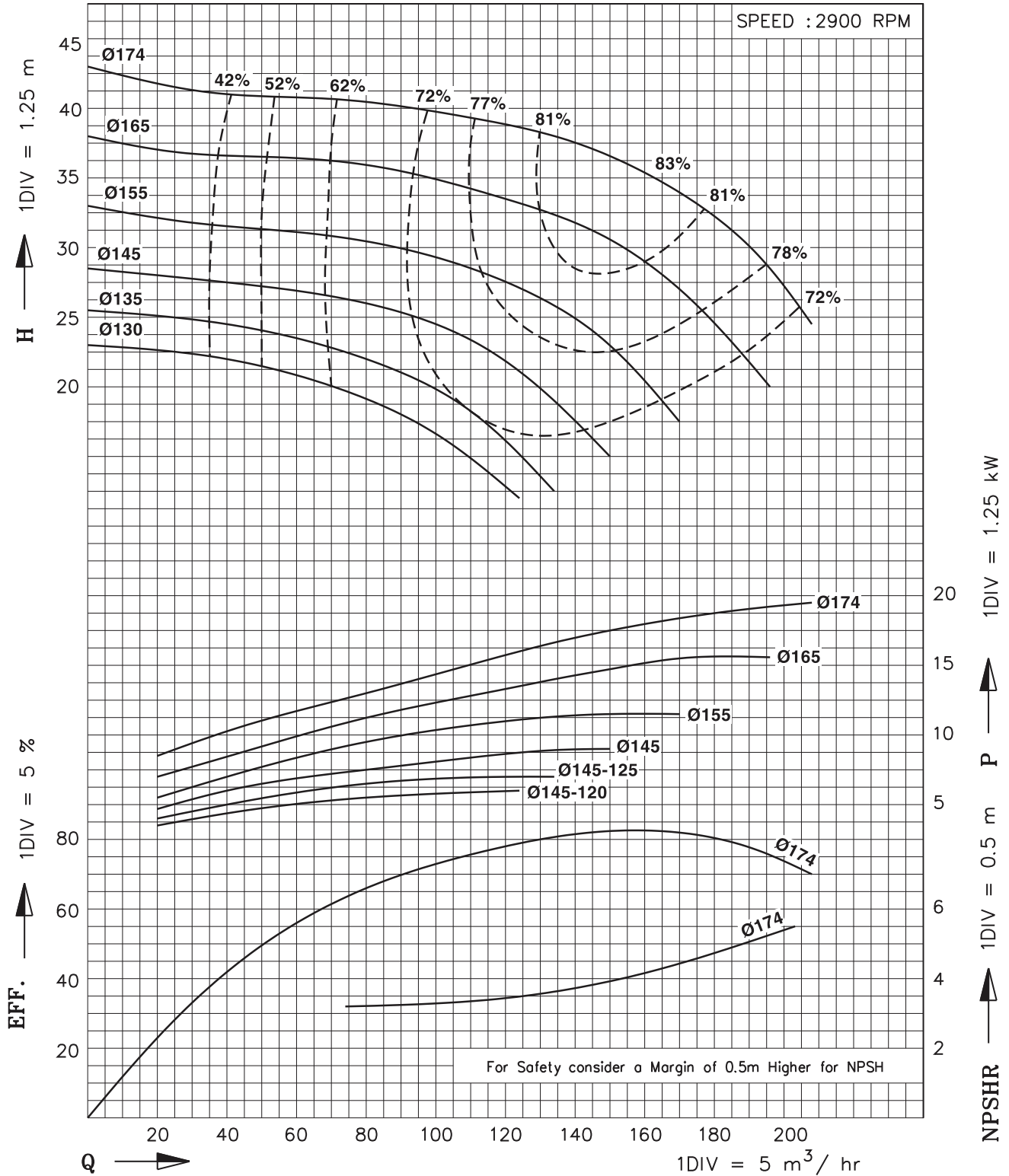

In view of continuous developments the information / performance / descriptions / specifications / Illustrations mentioned in this catalogues are subject to change without notice.



PERFORMANCE CURVE

Model : ECW-80/200

Note : Performance curve are as per specific gravity and viscosity of water.

SIZE : 100 x 80

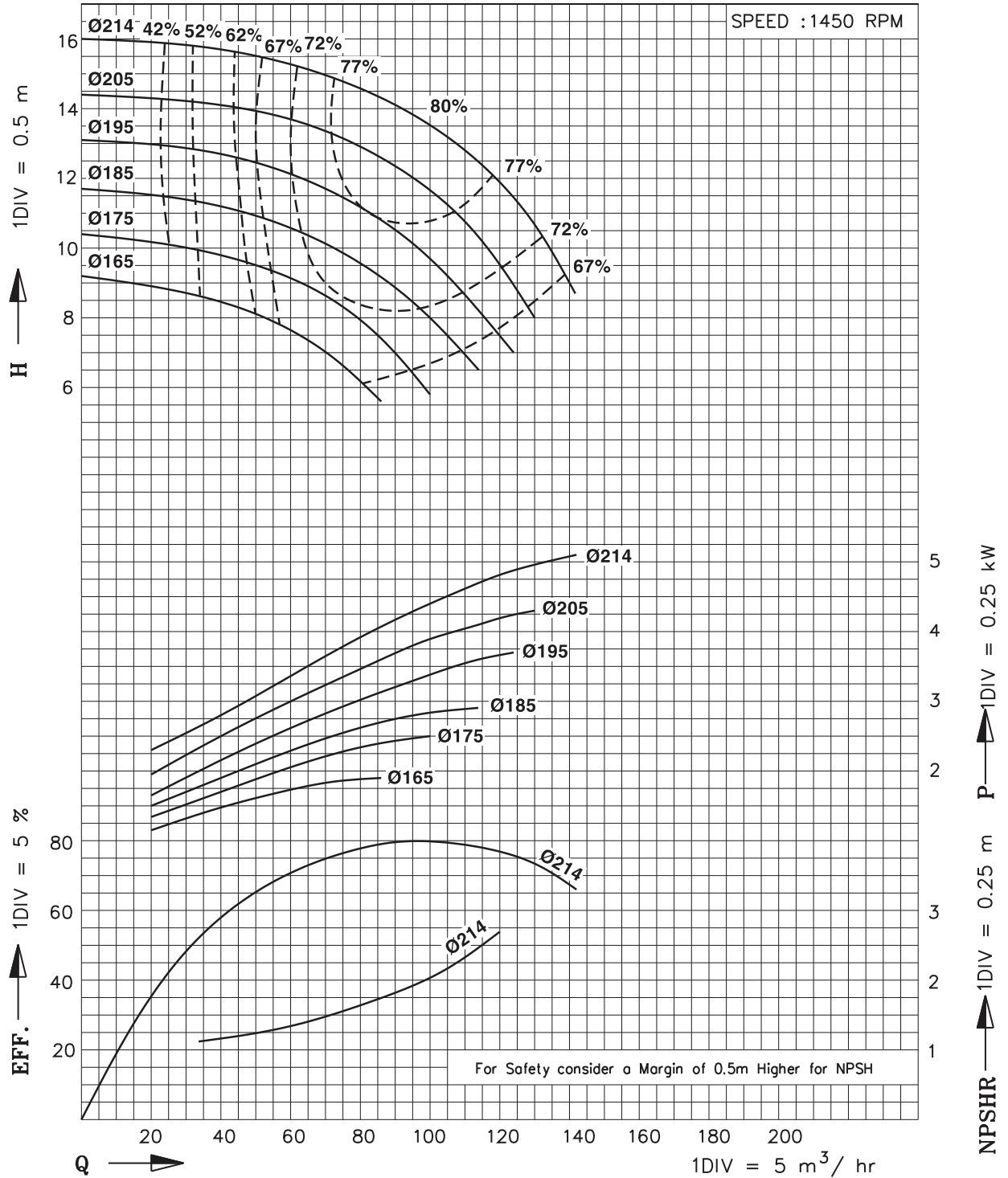



PERFORMANCE CURVE

Model : ECW-80/200

Note : Performance curve are as per specific gravity and viscosity of water.

SIZE : 100 x 80

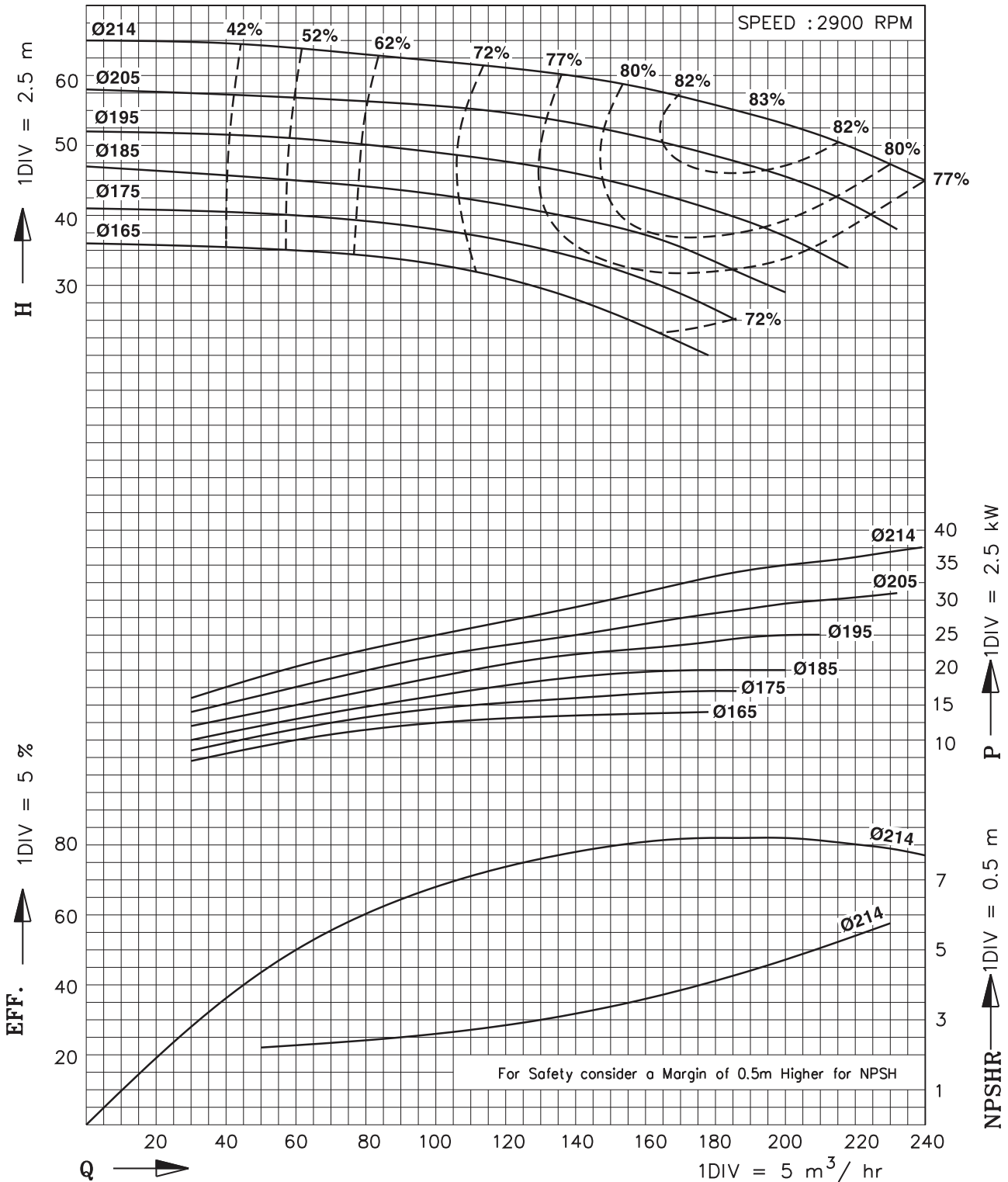



PERFORMANCE CURVE

Model : ECW-80/260

Note : Performance curve are as per specific gravity and viscosity of water.

SIZE : 100 x 80

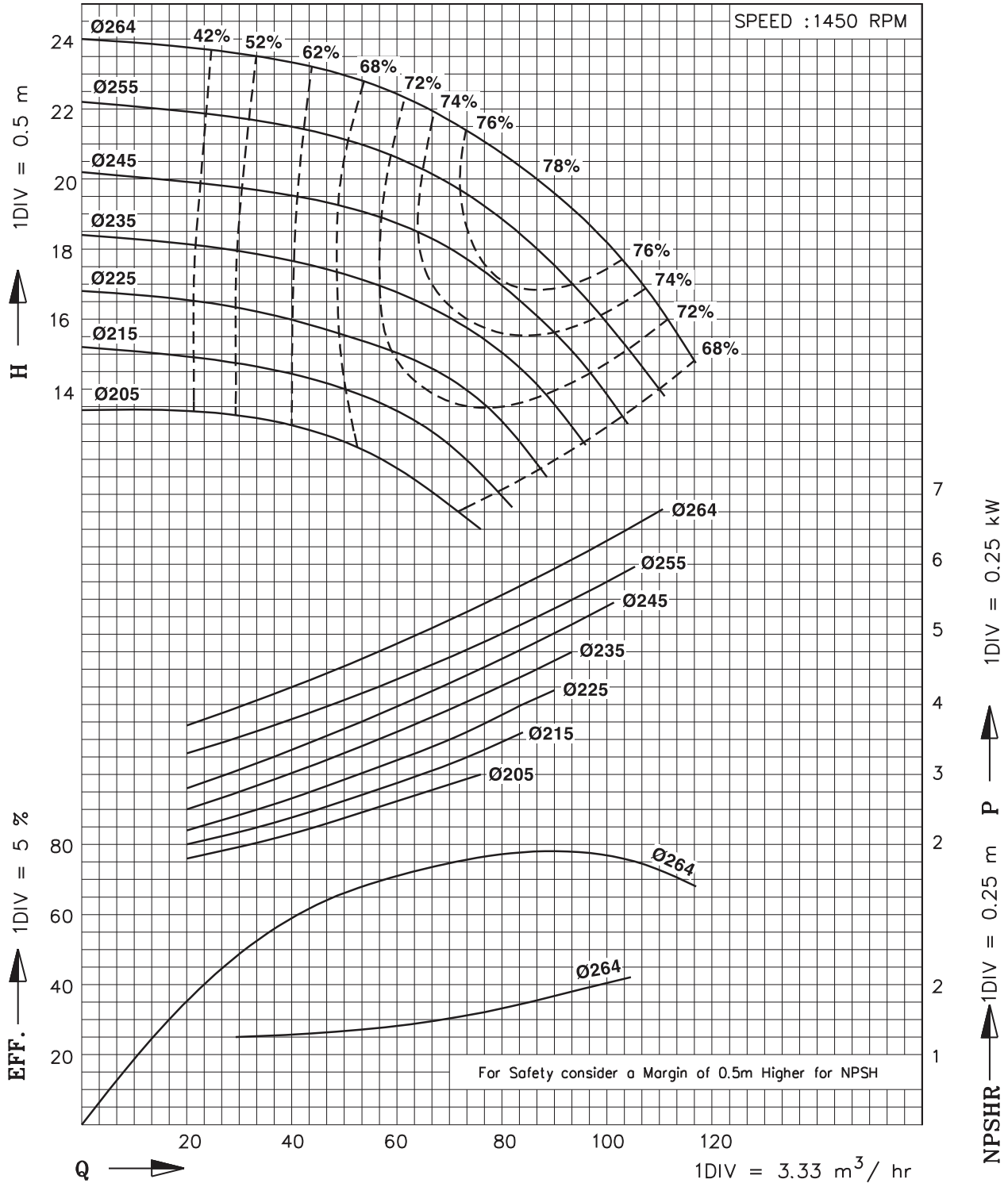



PERFORMANCE CURVE

Model : ECW-80/260

Note : Performance curve are as per specific gravity and viscosity of water.

SIZE : 100 x 80

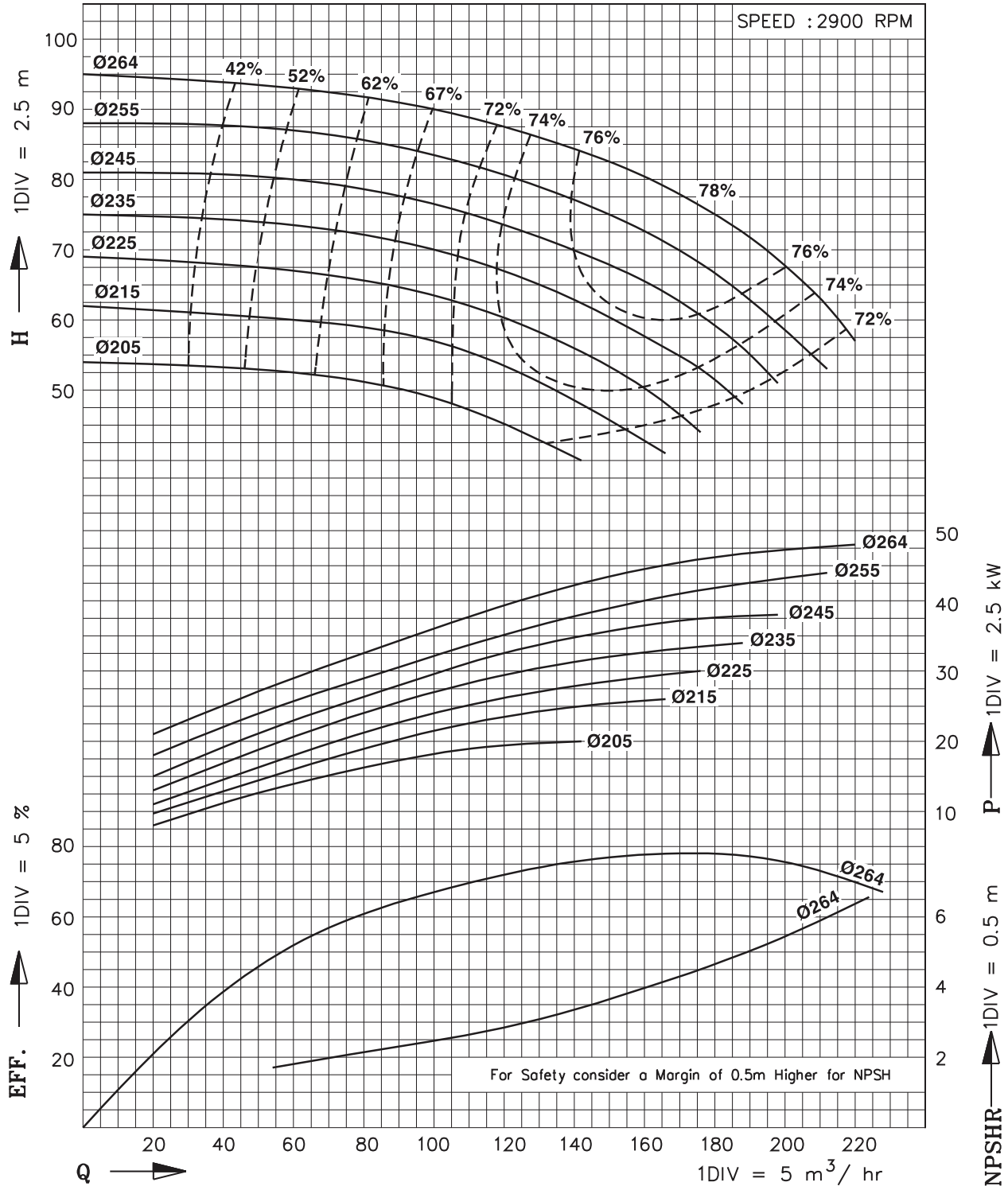



PERFORMANCE CURVE

Model : ECW-80/320

Note : Performance curve are as per specific gravity and viscosity of water.

SIZE : 100 x 80

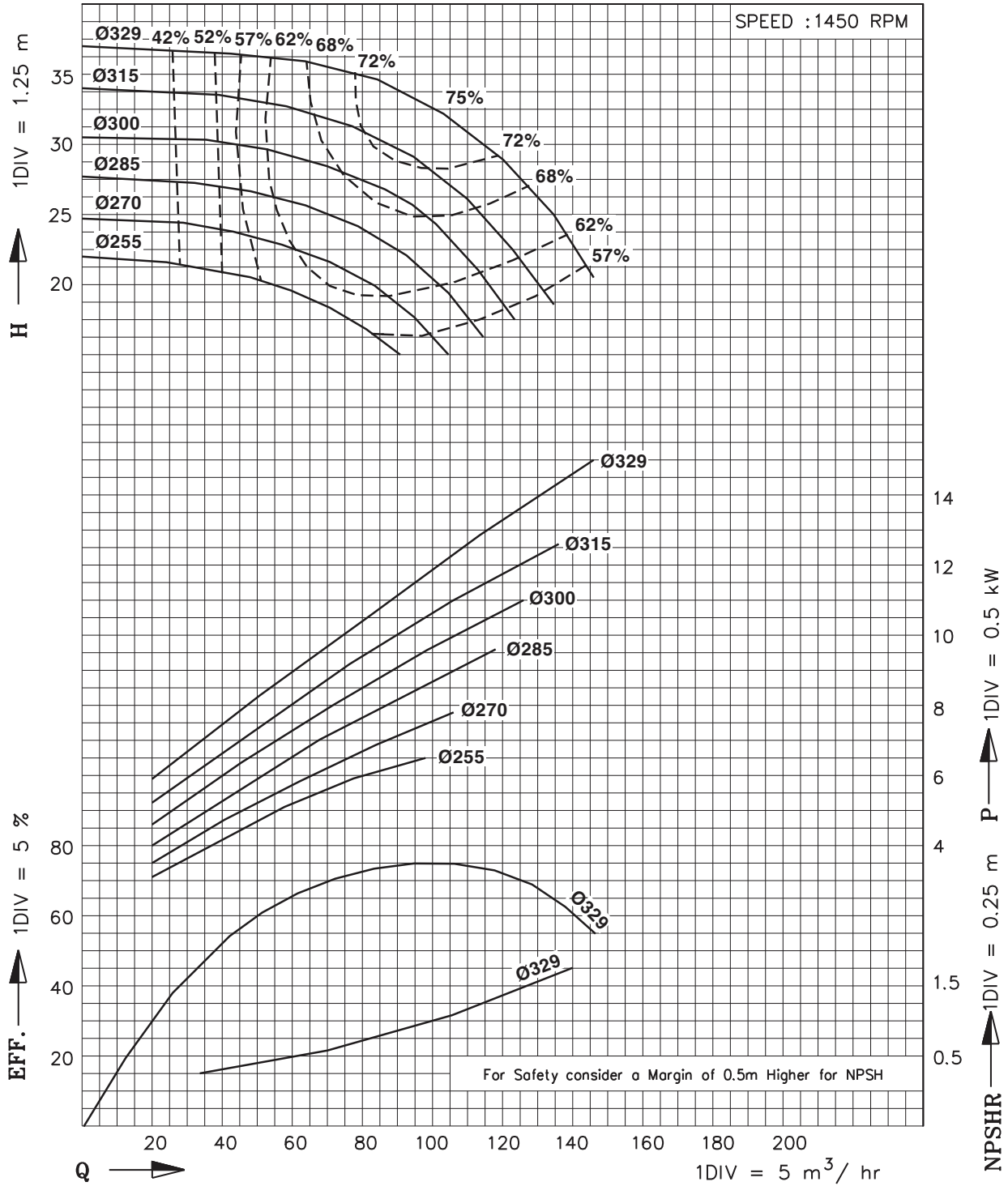



PERFORMANCE CURVE

Model : **ECW-80/320**-On request

Note : Performance curve are as per specific gravity and viscosity of water.

SIZE : **100 x 80**

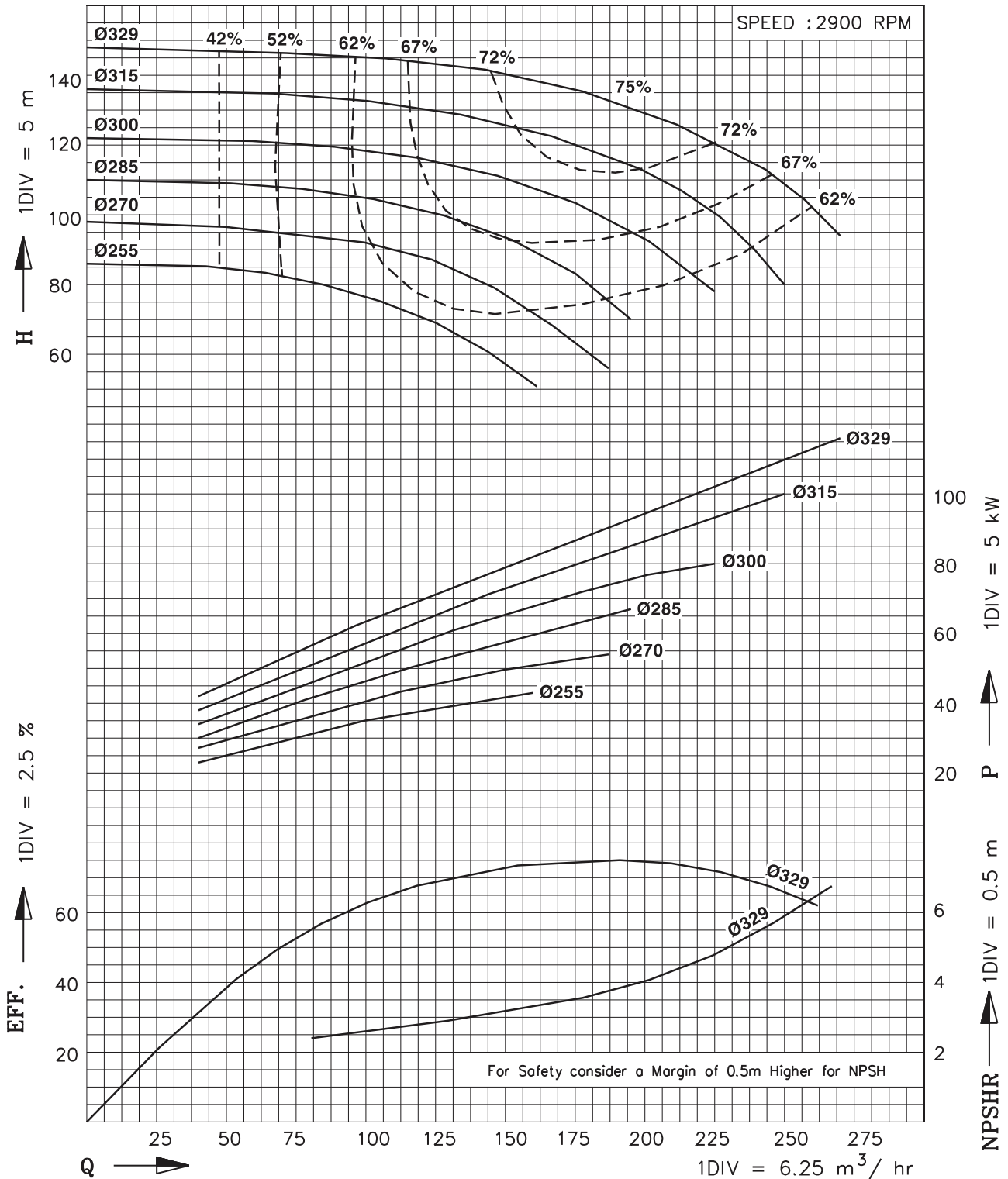



PERFORMANCE CURVE

Model : ECW-80/400

Note : Performance curve are as per specific gravity and viscosity of water.

SIZE : 125 x 80

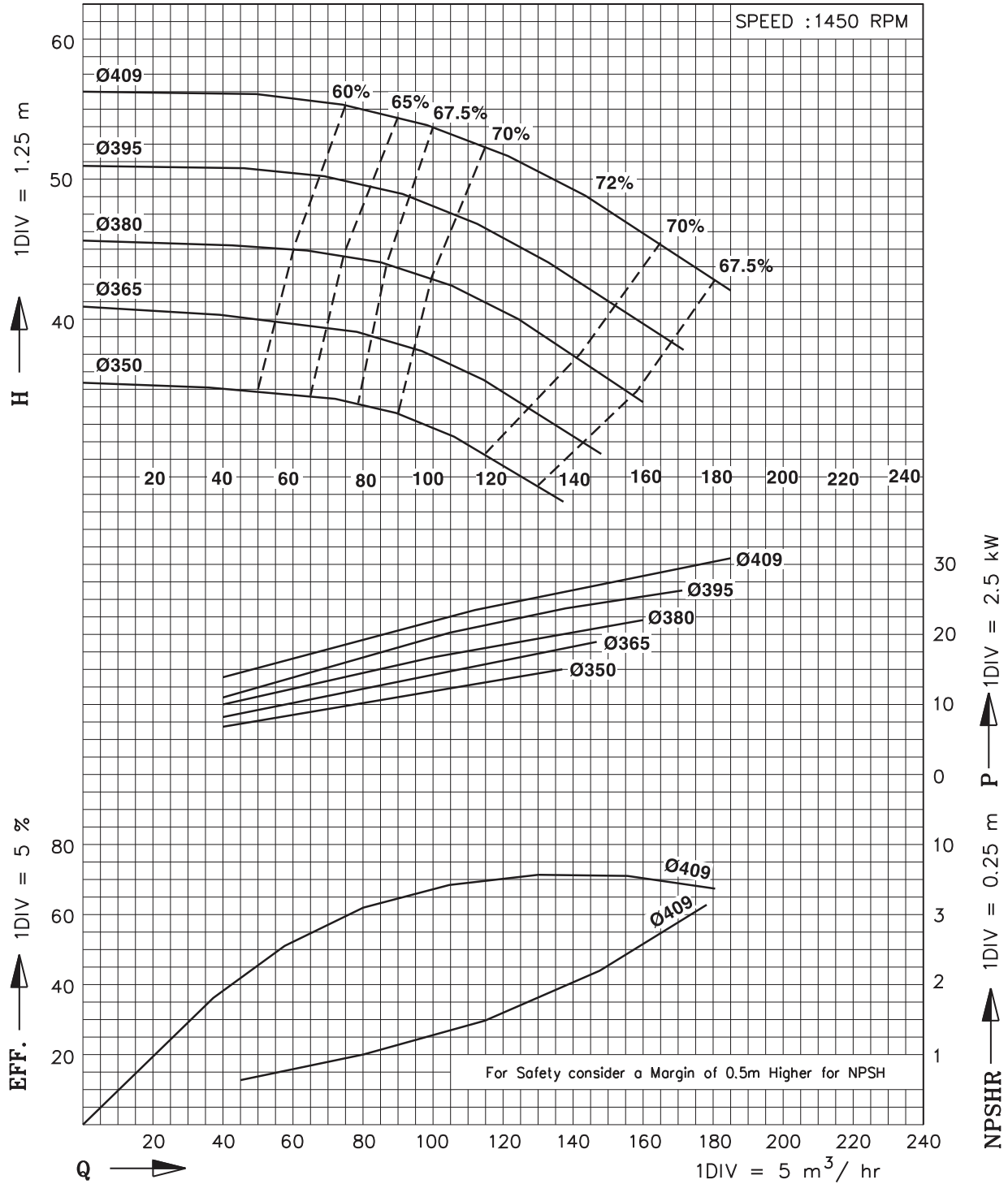

In view of continuous developments the information / performance / descriptions / specifications / Illustrations mentioned in this catalogues are subject to change without notice.



PERFORMANCE CURVE

Model : ECW-100/200

Note : Performance curve are as per specific gravity and viscosity of water.

SIZE : 125 x 100

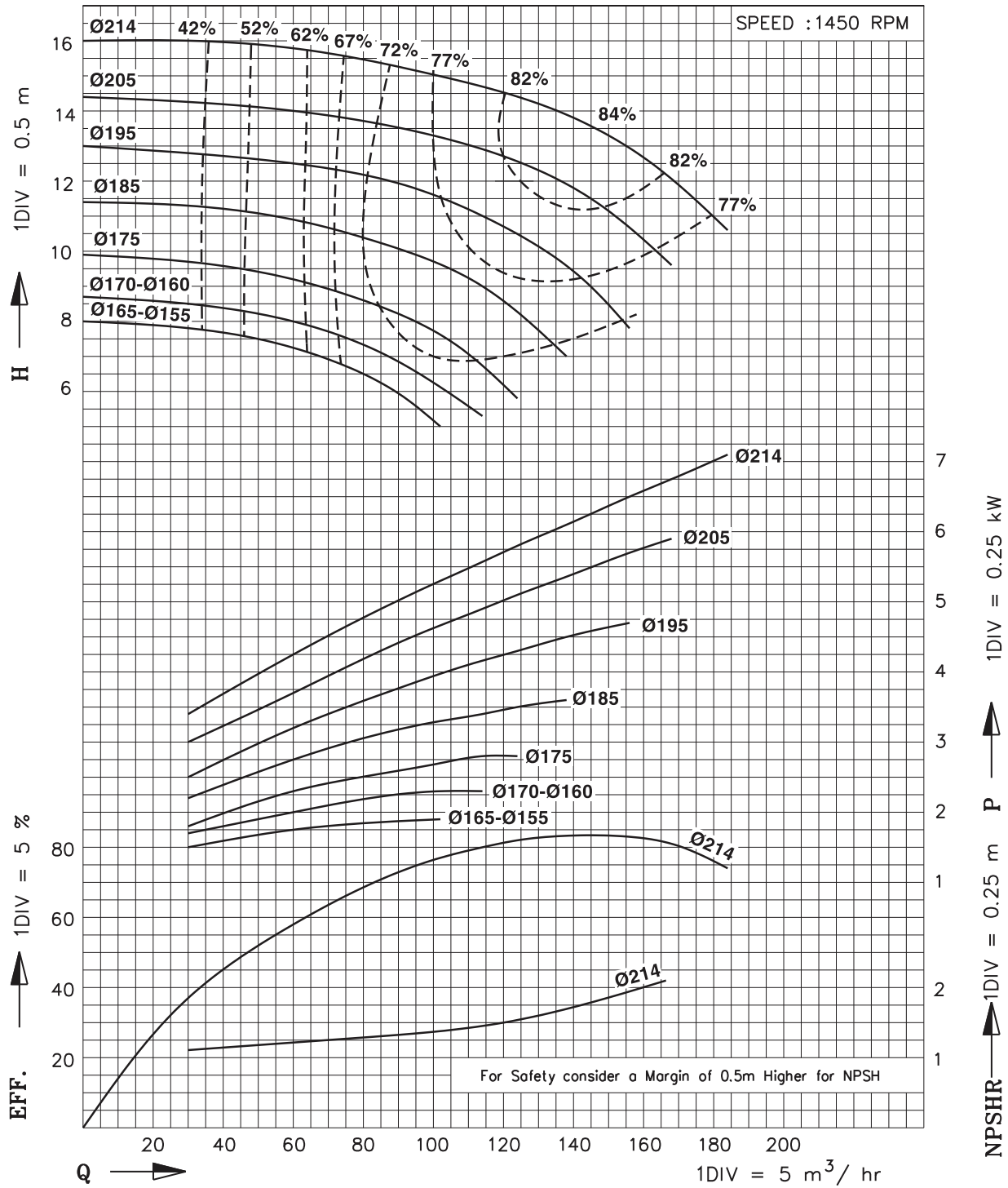



PERFORMANCE CURVE

Model : ECW-100/200

Note : Performance curve are as per specific gravity and viscosity of water.

SIZE : 125 x 100

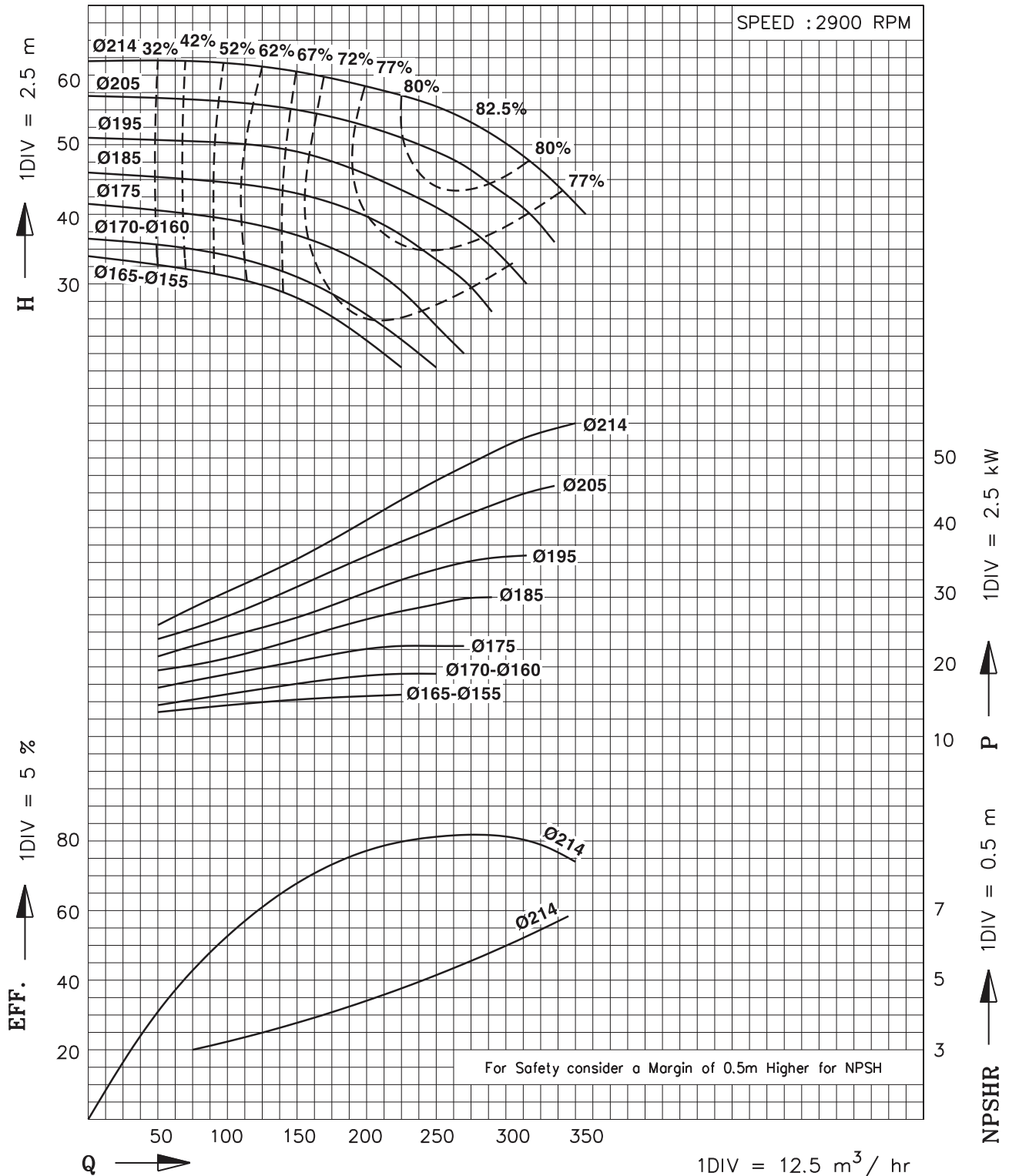

In view of continuous developments the information / performance / descriptions / specifications / Illustrations mentioned in this catalogues are subject to change without notice.



PERFORMANCE CURVE

Model : ECW-100/260

Note : Performance curve are as per specific gravity and viscosity of water.

SIZE : 125 x 100

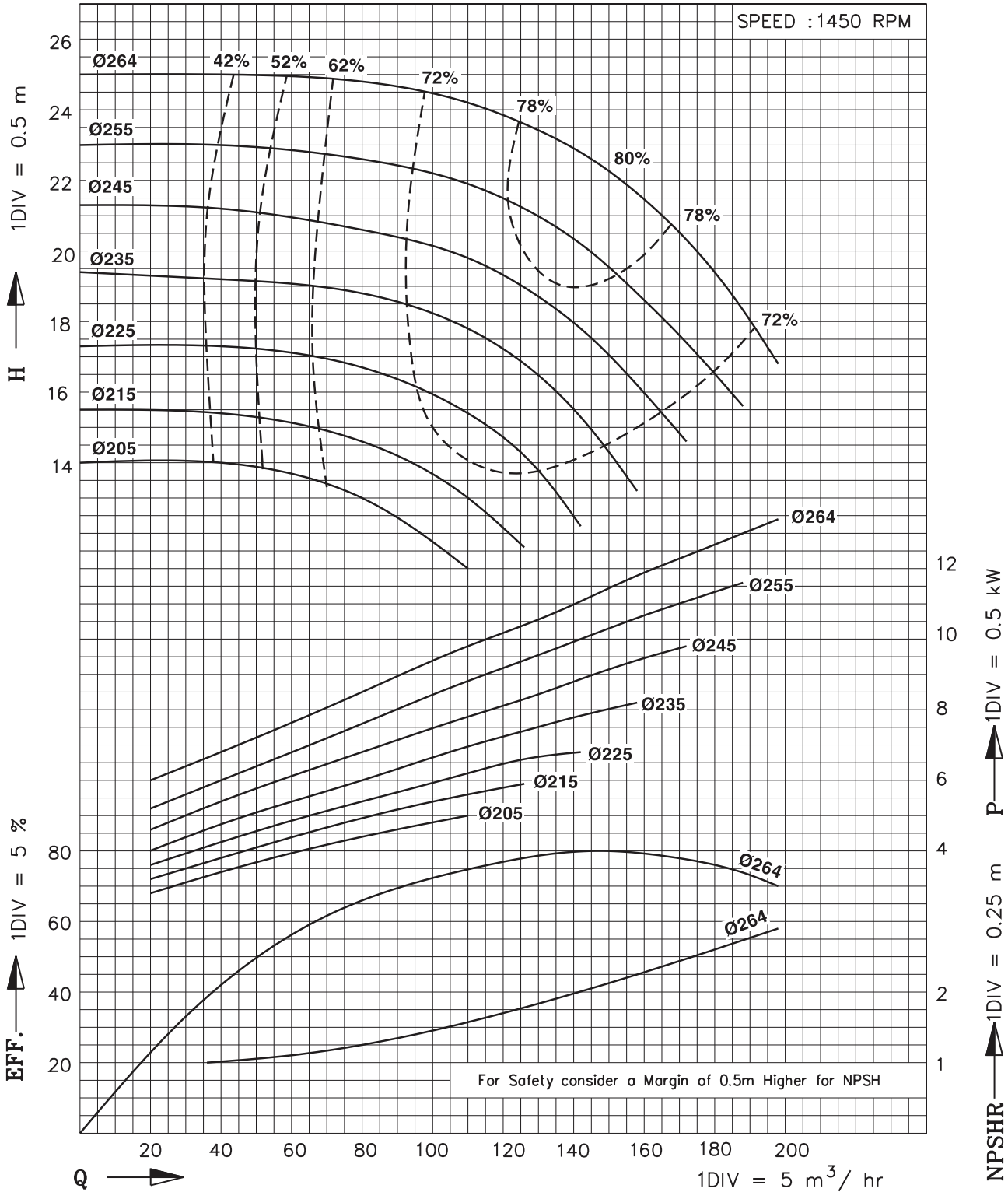



PERFORMANCE CURVE

Model : ECW-100/260

Note : Performance curve are as per specific gravity and viscosity of water.

SIZE : 125 x 100

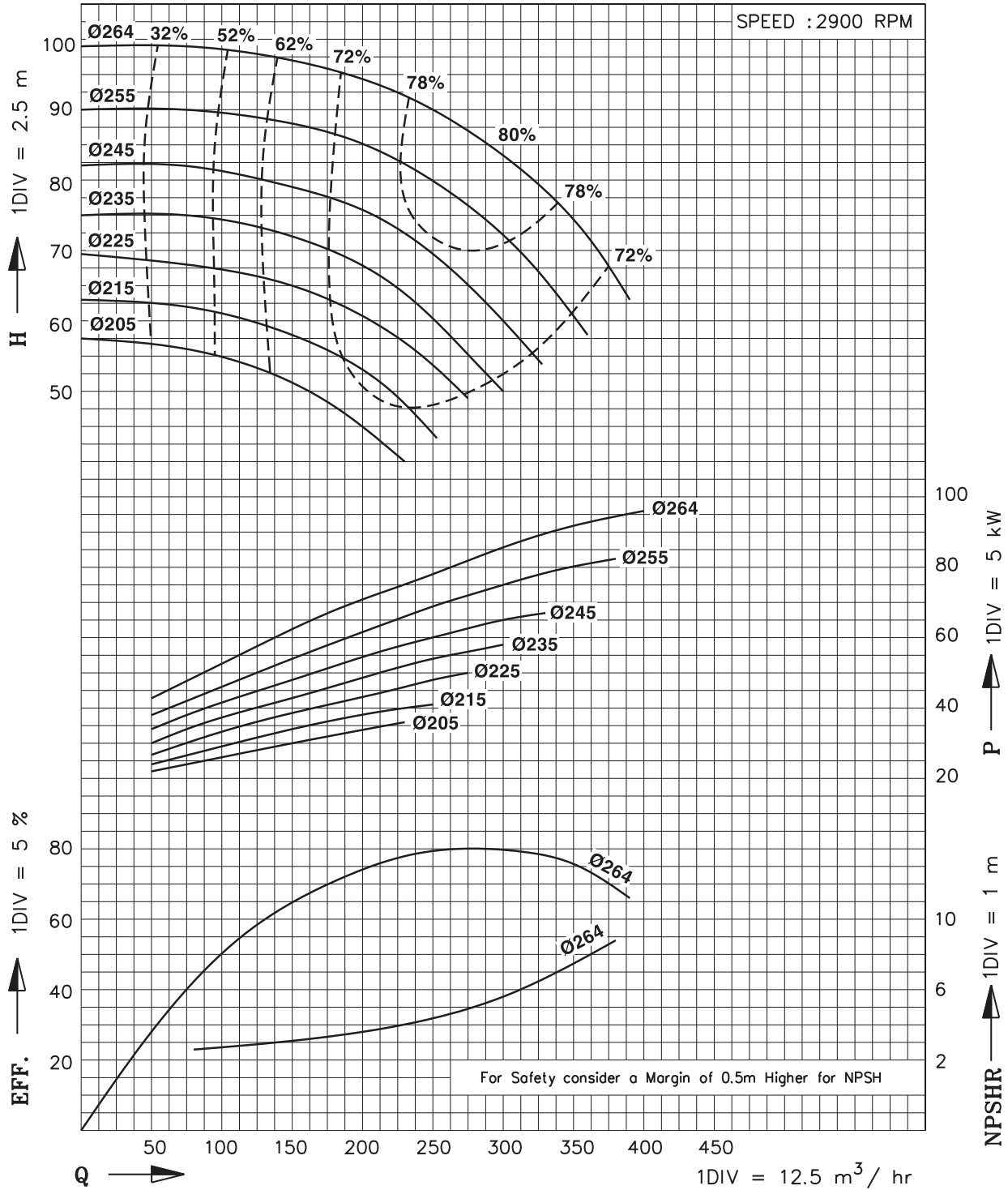



PERFORMANCE CURVE

Model : ECW-100/320

Note : Performance curve are as per specific gravity and viscosity of water.

SIZE : 125 x 100

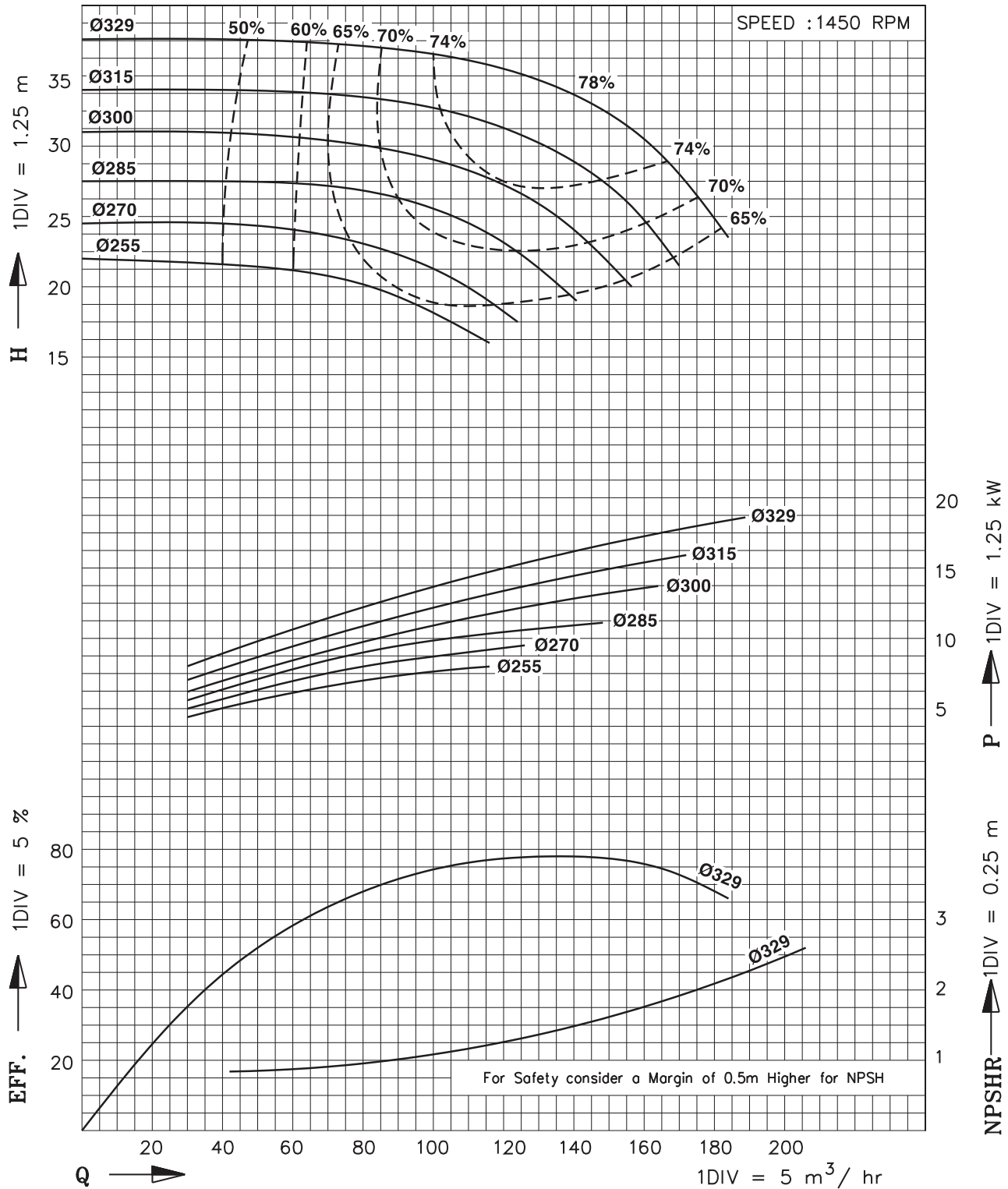



PERFORMANCE CURVE

Model : ECW-100/320-On request

Note : Performance curve are as per specific gravity and viscosity of water.

SIZE : 125 x 100

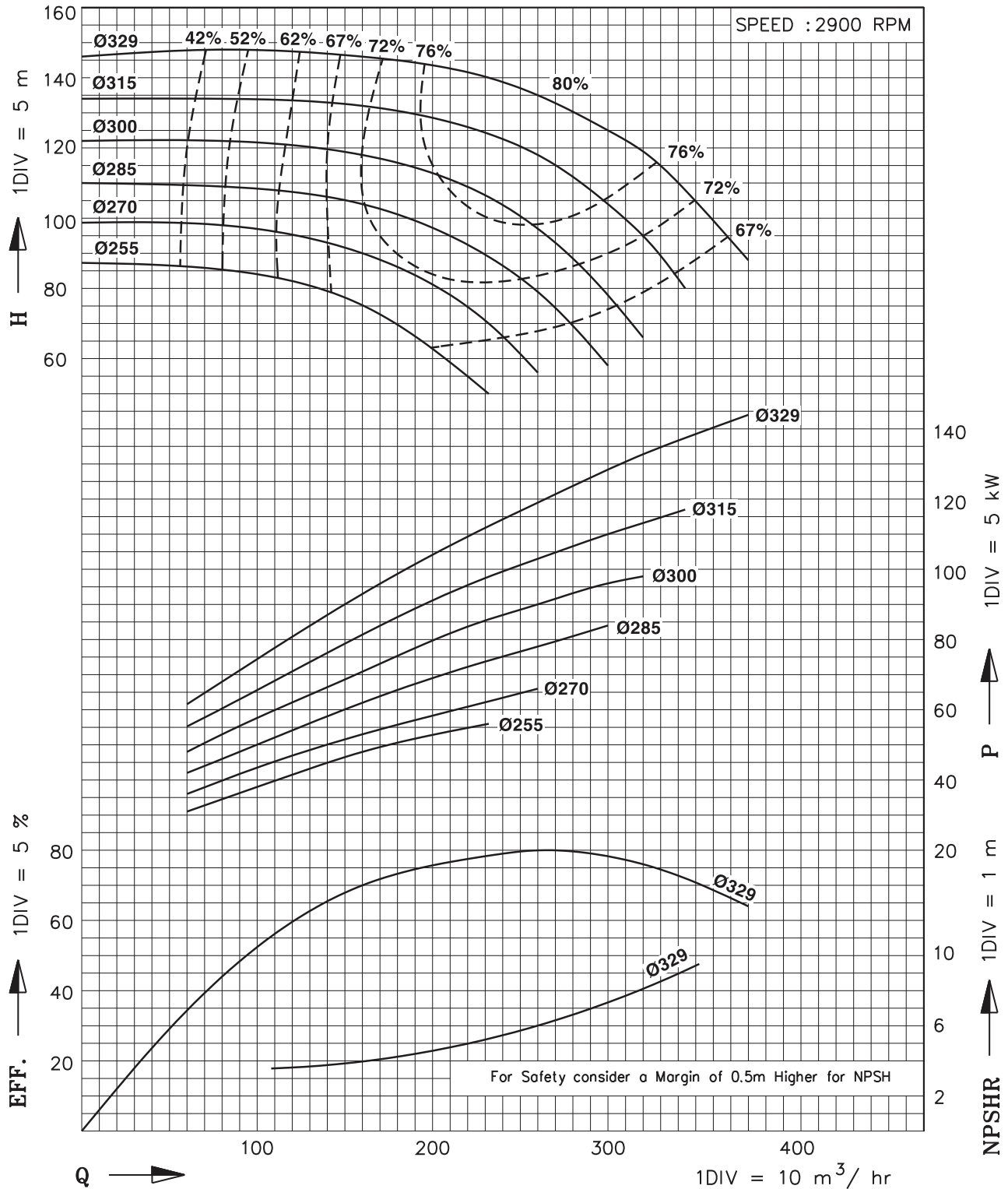

In view of continuous developments the information / performance / descriptions / specifications / Illustrations mentioned in this catalogues are subject to change without notice.



PERFORMANCE CURVE

Model : ECW-100/400

Note : Performance curve are as per specific gravity and viscosity of water.

SIZE : 125 x 100

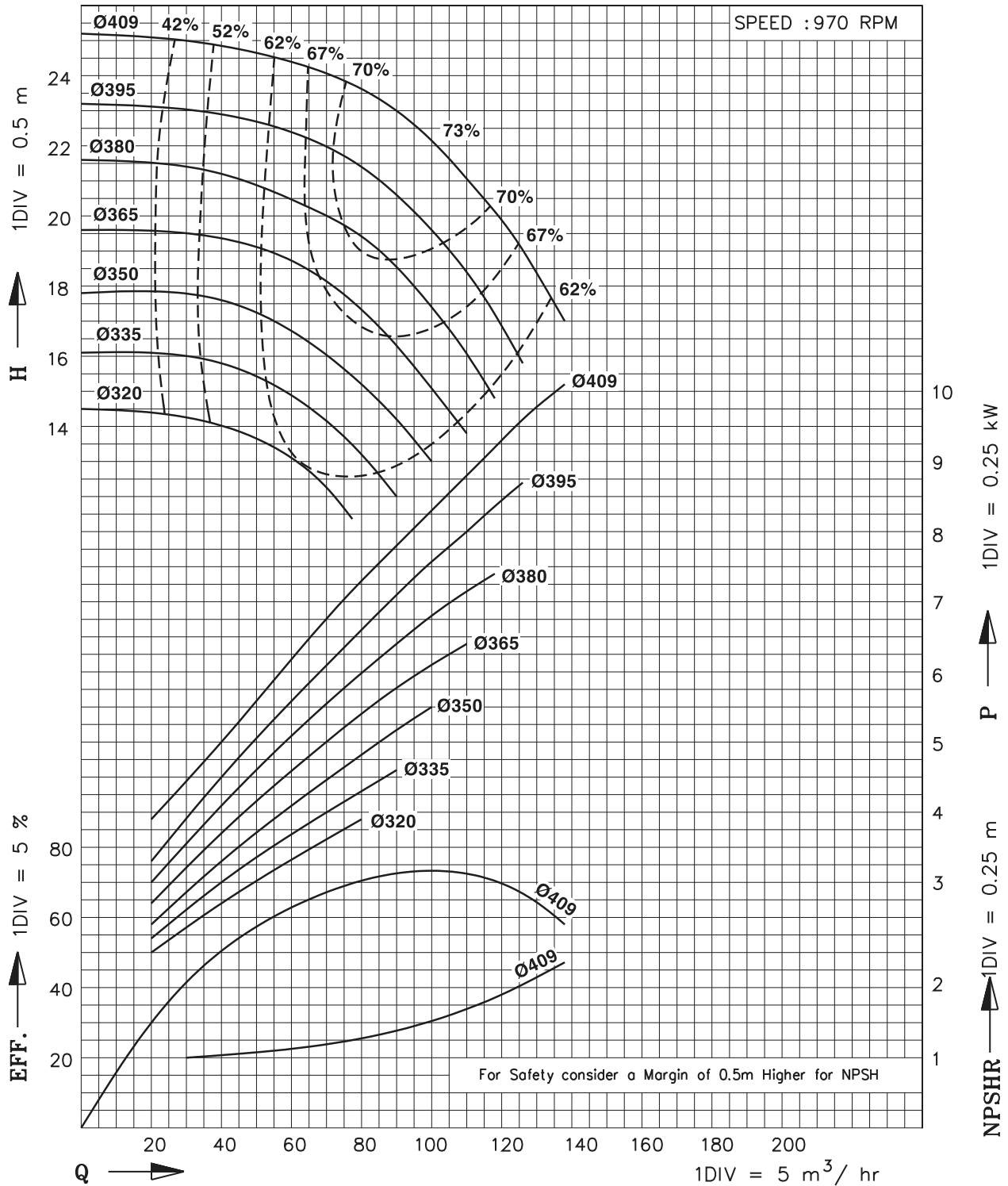



PERFORMANCE CURVE

Model : ECW-100/400

Note : Performance curve are as per specific gravity and viscosity of water.

SIZE : 125 x 100

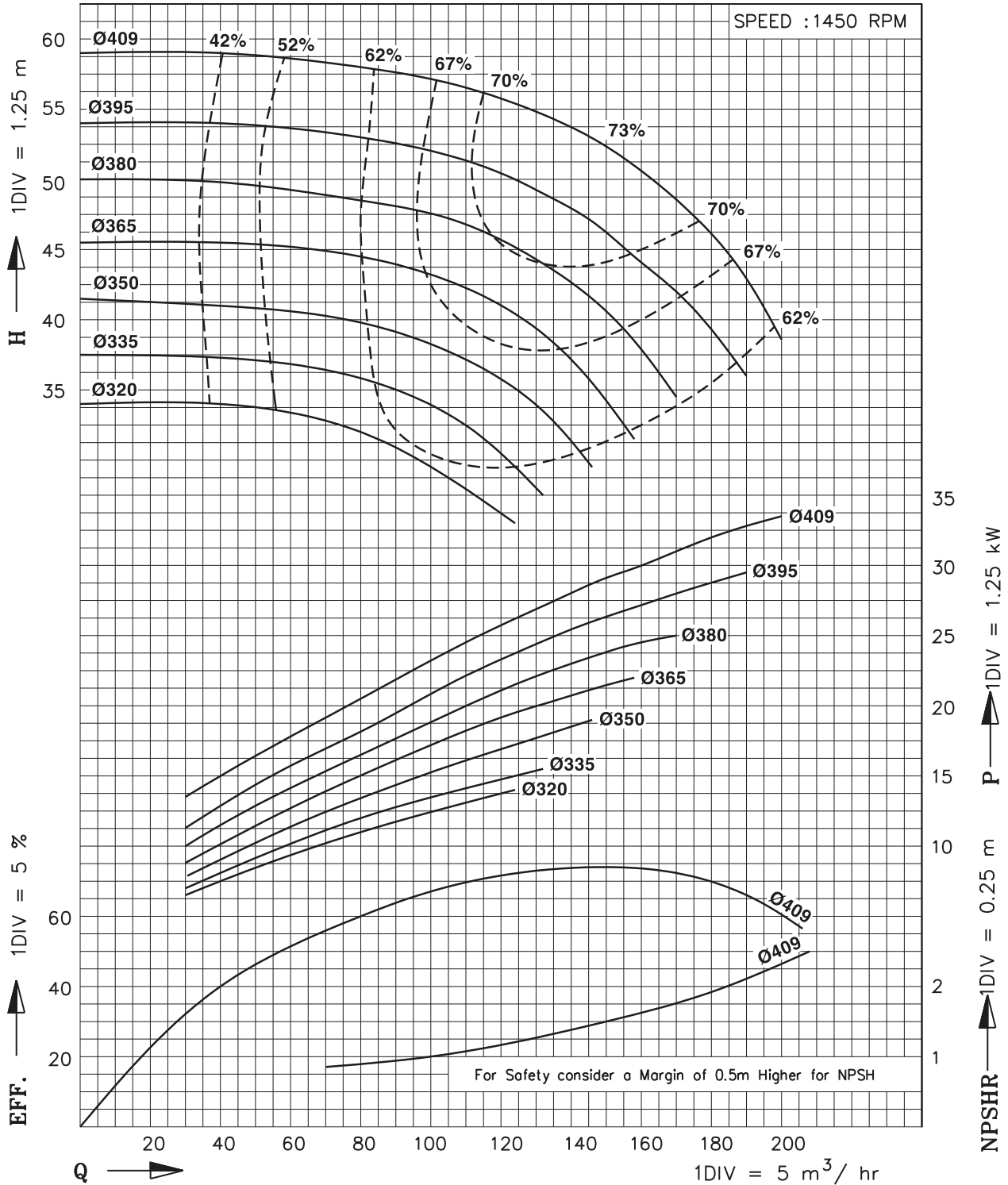



PERFORMANCE CURVE

Model : ECW-125/260

Note : Performance curve are as per specific gravity and viscosity of water.

SIZE : 150 x 125

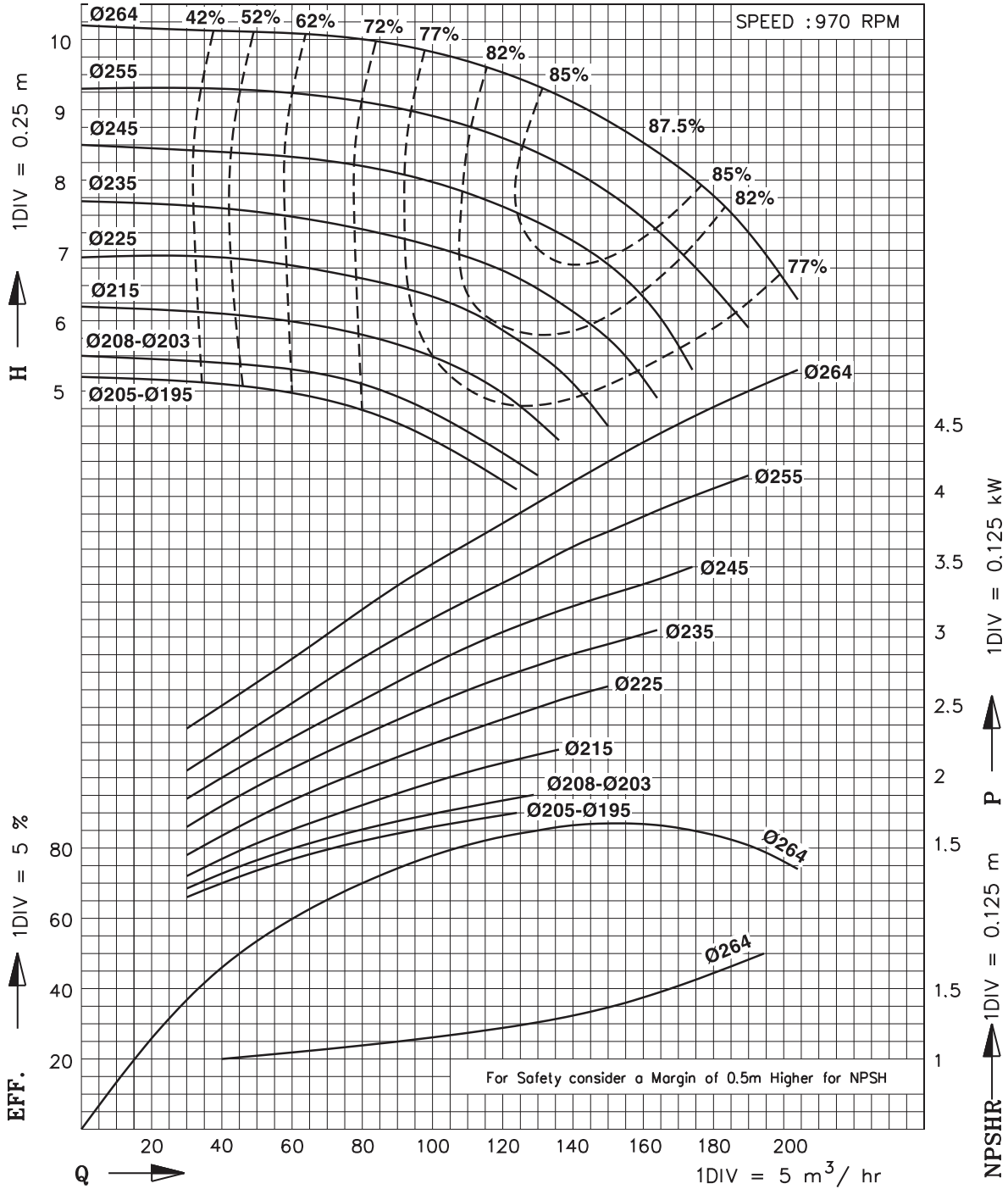



PERFORMANCE CURVE

Model : ECW-125/260

Note : Performance curve are as per specific gravity and viscosity of water.

SIZE : 150 x 125

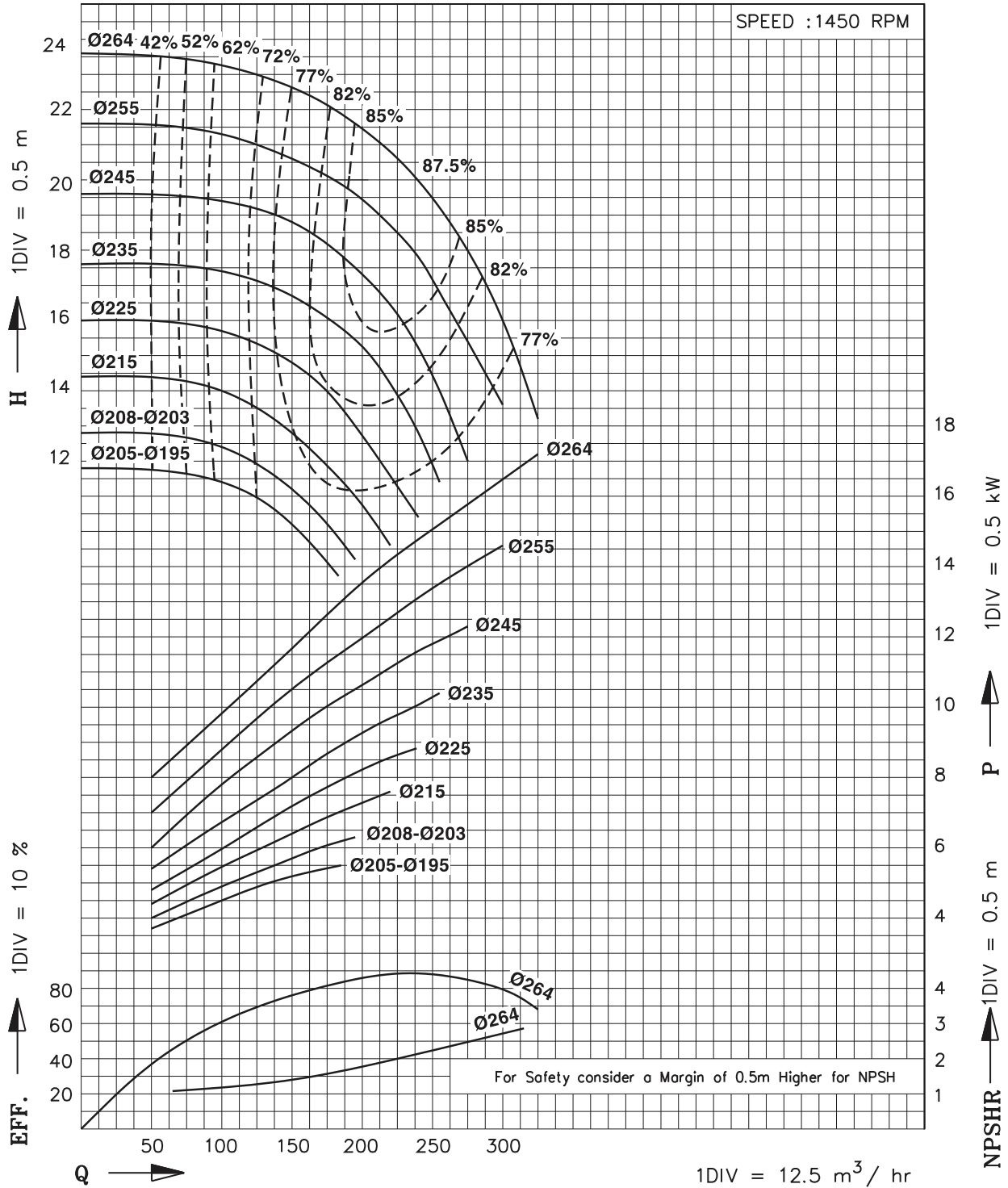



PERFORMANCE CURVE

Model : ECW-125/320

Note : Performance curve are as per specific gravity and viscosity of water.

SIZE : 150 x 125

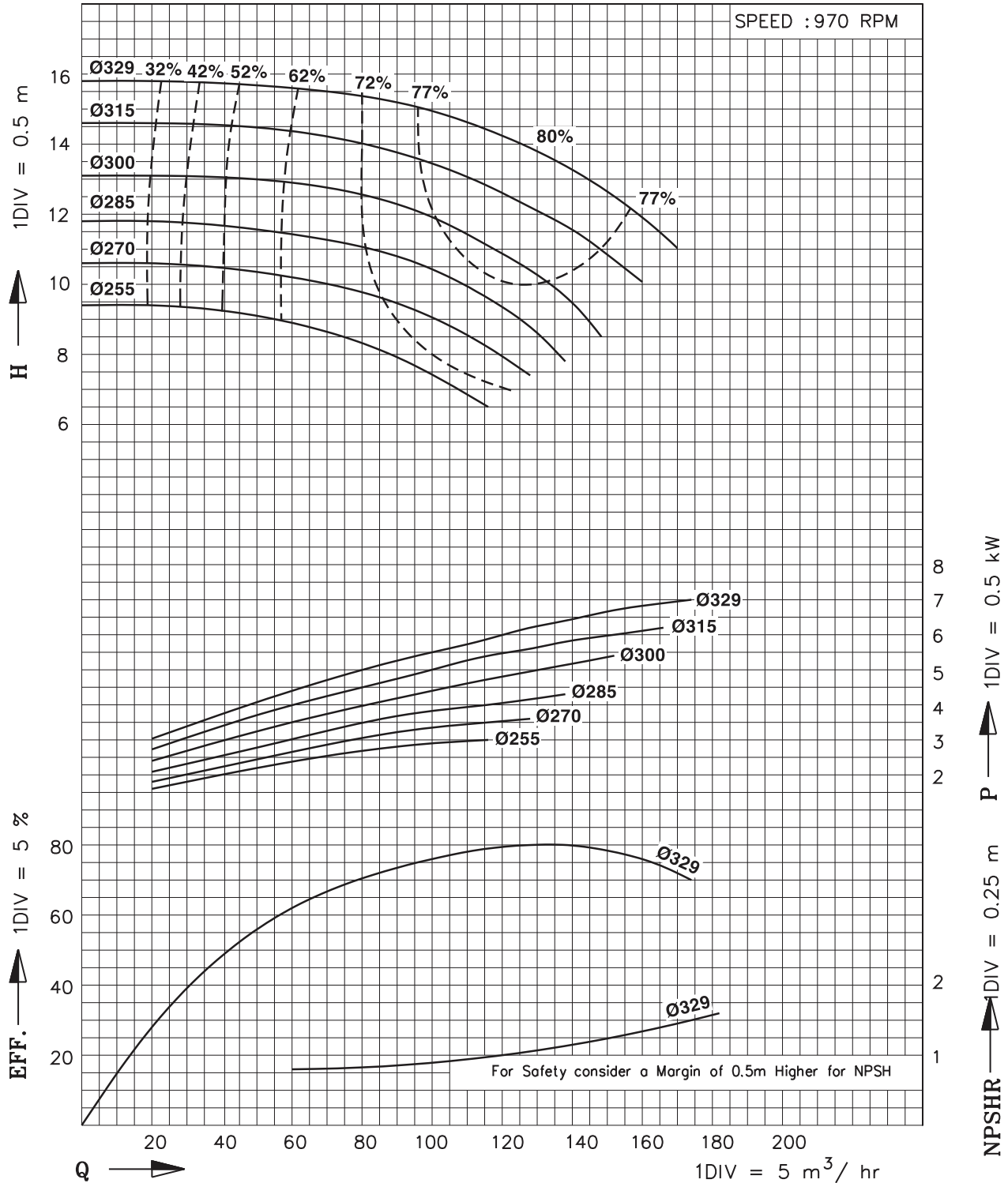



PERFORMANCE CURVE

Model : ECW-125/320

Note : Performance curve are as per specific gravity and viscosity of water.

SIZE : 150 x 125

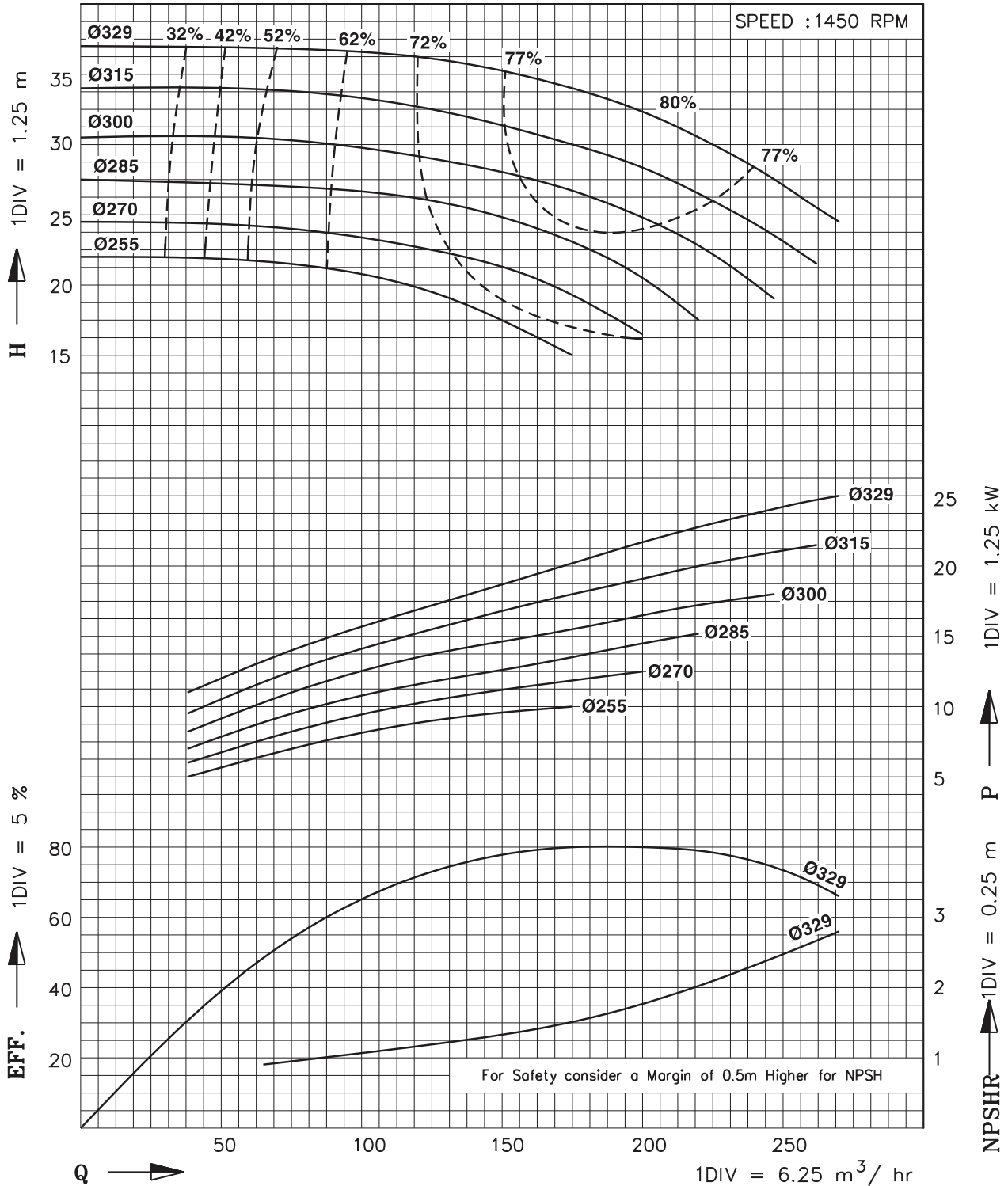



PERFORMANCE CURVE

Model : ECW-125/400

Note : Performance curve are as per specific gravity and viscosity of water.

SIZE : 150 x 125

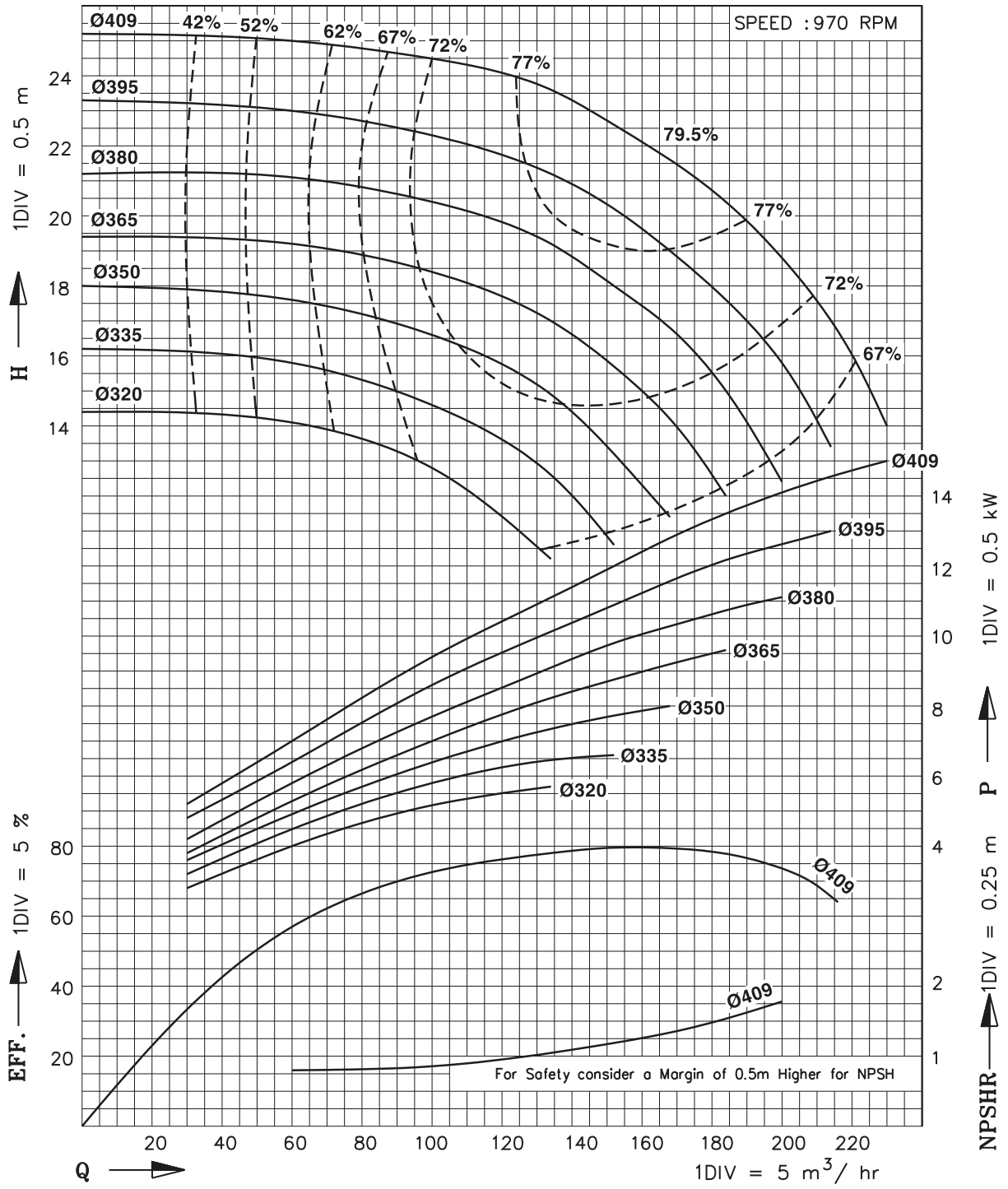



PERFORMANCE CURVE

Model : ECW-125/400

Note : Performance curve are as per specific gravity and viscosity of water.

SIZE : 150 x 125

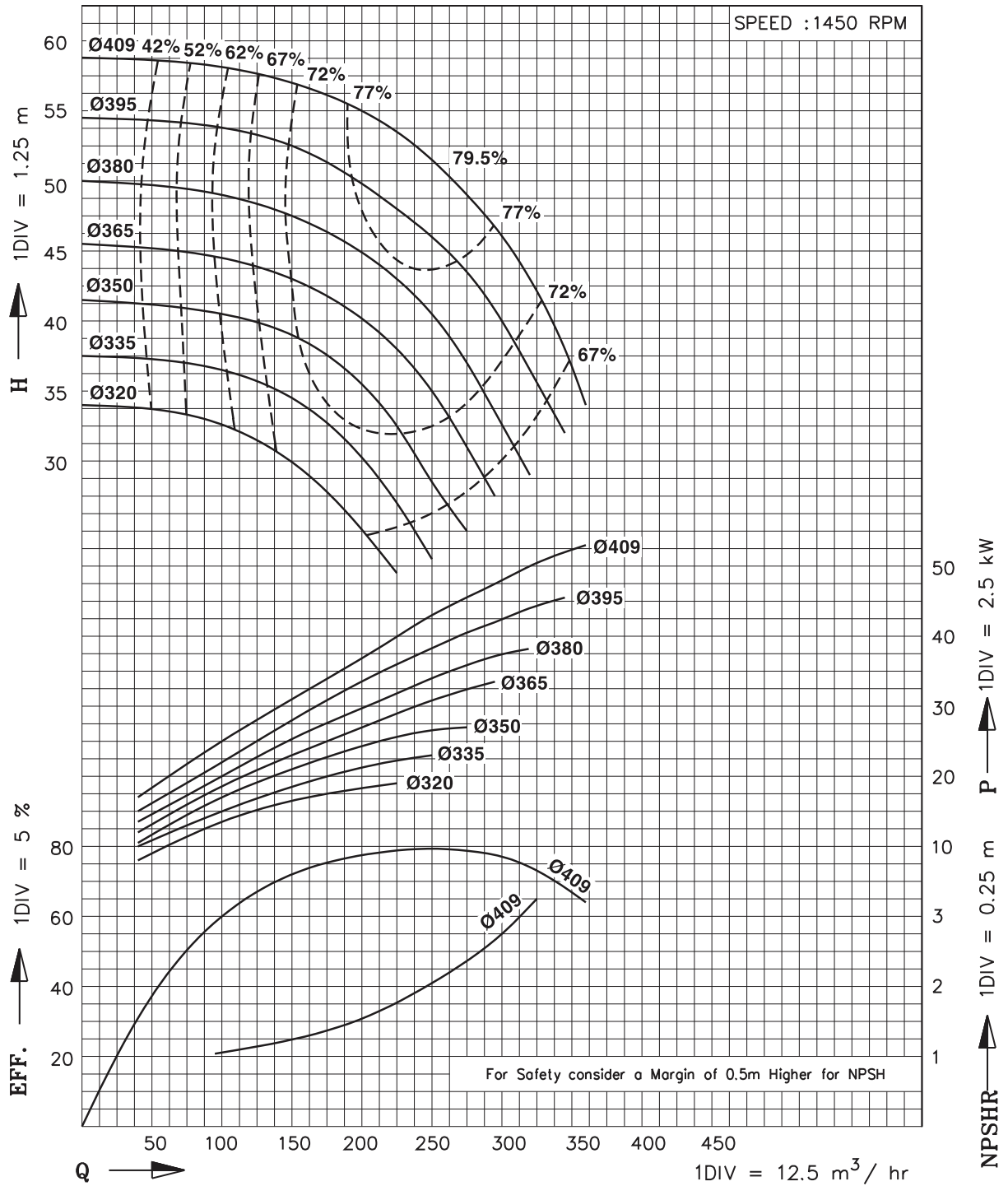



PERFORMANCE CURVE

Model : ECW-150/260

Note : Performance curve are as per specific gravity and viscosity of water.

SIZE : 200 x 150

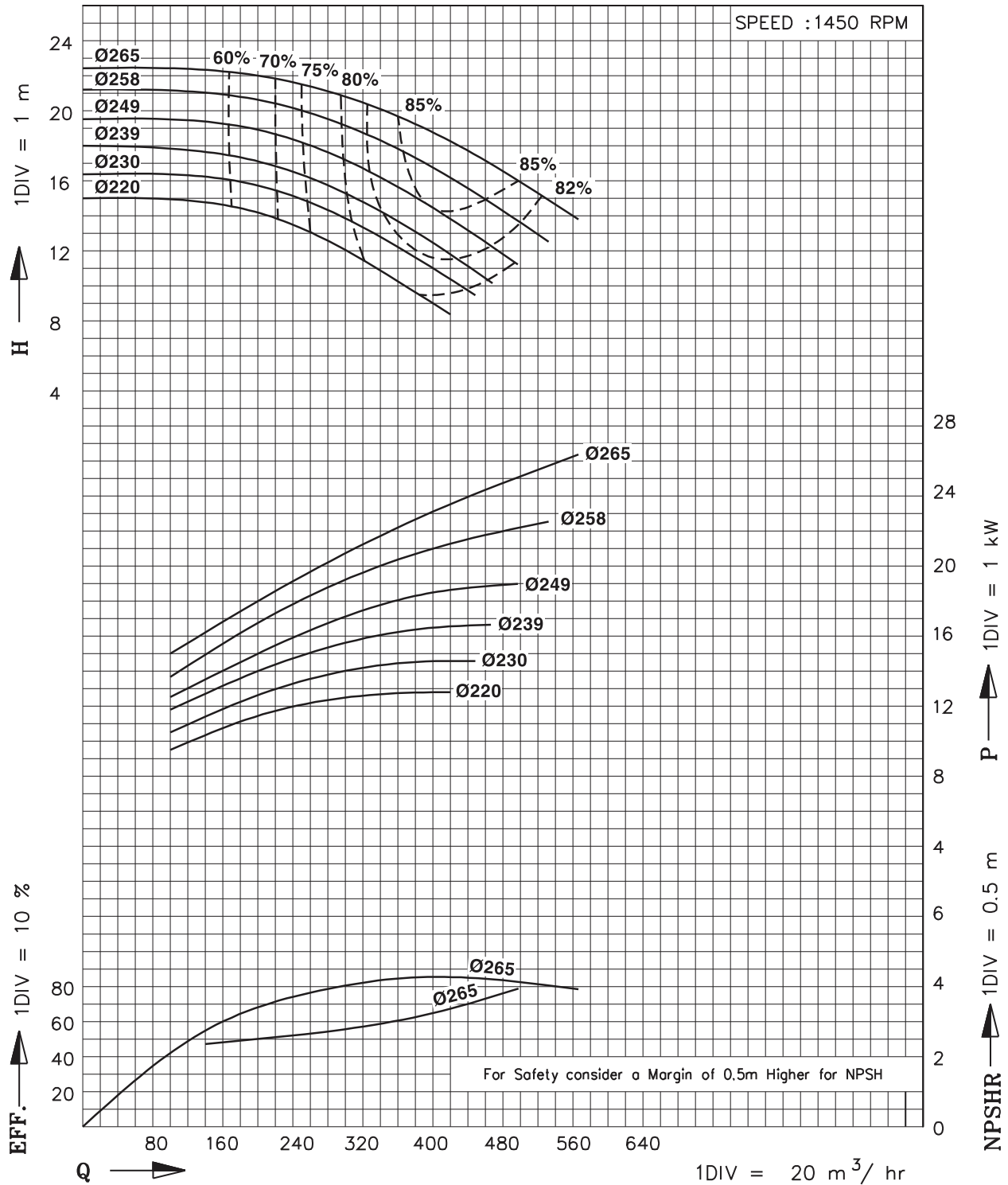



PERFORMANCE CURVE

Model : ECW-150/320

Note : Performance curve are as per specific gravity and viscosity of water.

SIZE : 200 x 150

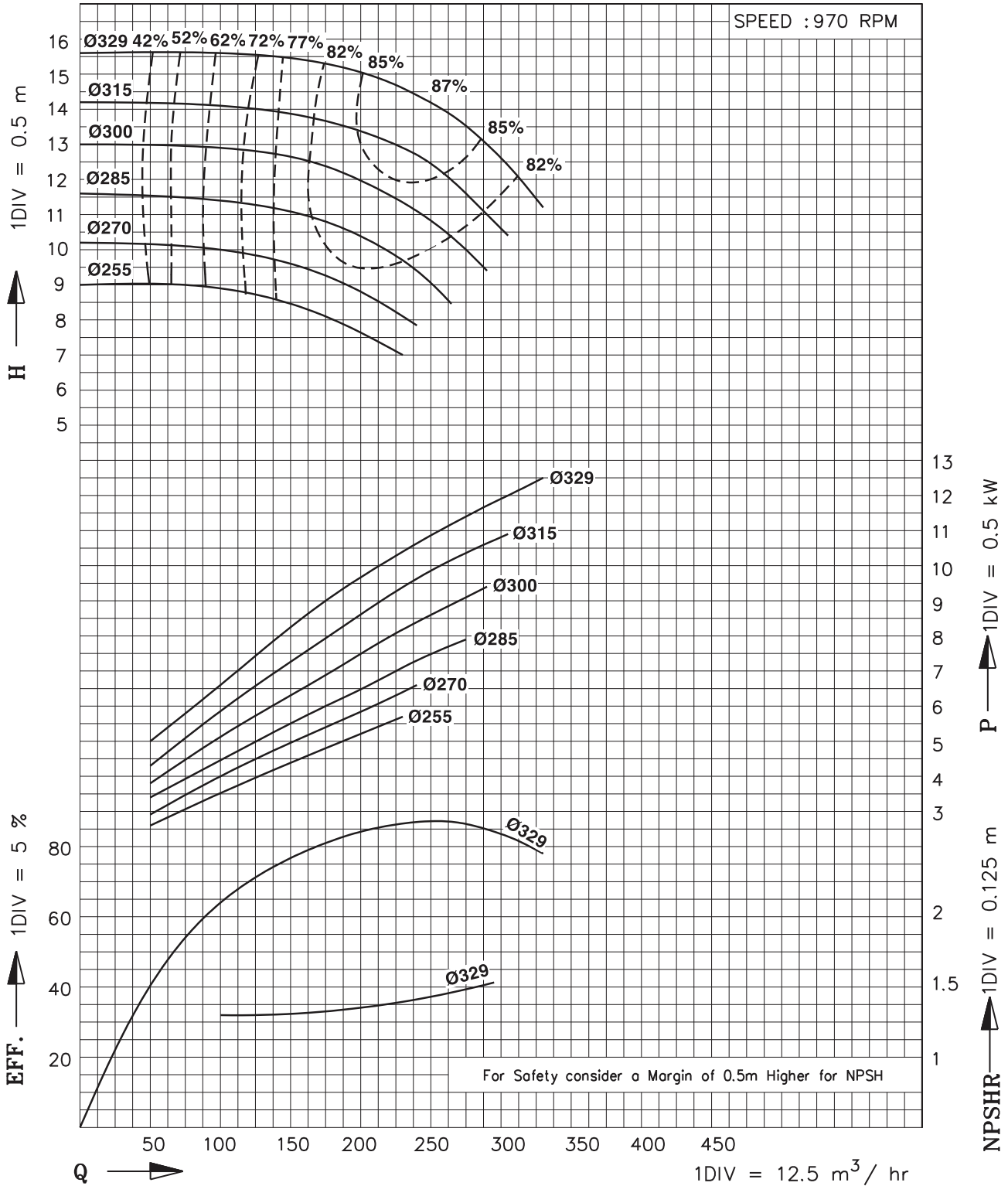

In view of continuous developments the information / performance / descriptions / specifications / Illustrations mentioned in this catalogues are subject to change without notice.



PERFORMANCE CURVE

Model : ECW-150/320

Note : Performance curve are as per specific gravity and viscosity of water.

SIZE : 200 x 150

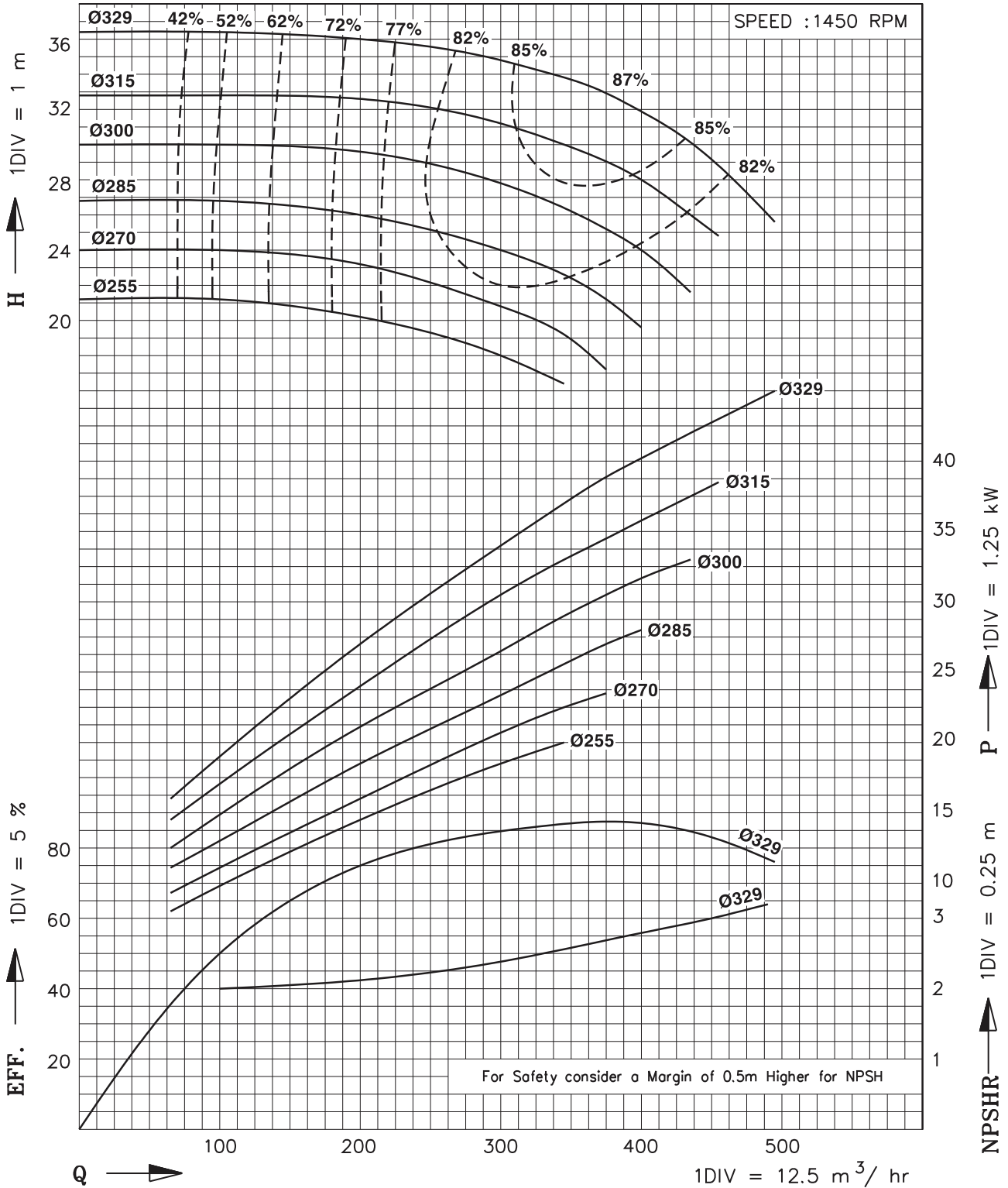

In view of continuous developments the information / performance / descriptions / specifications / Illustrations mentioned in this catalogues are subject to change without notice.



PERFORMANCE CURVE

Model : ECW-150/400

Note : Performance curve are as per specific gravity and viscosity of water.

SIZE : 200 x 150

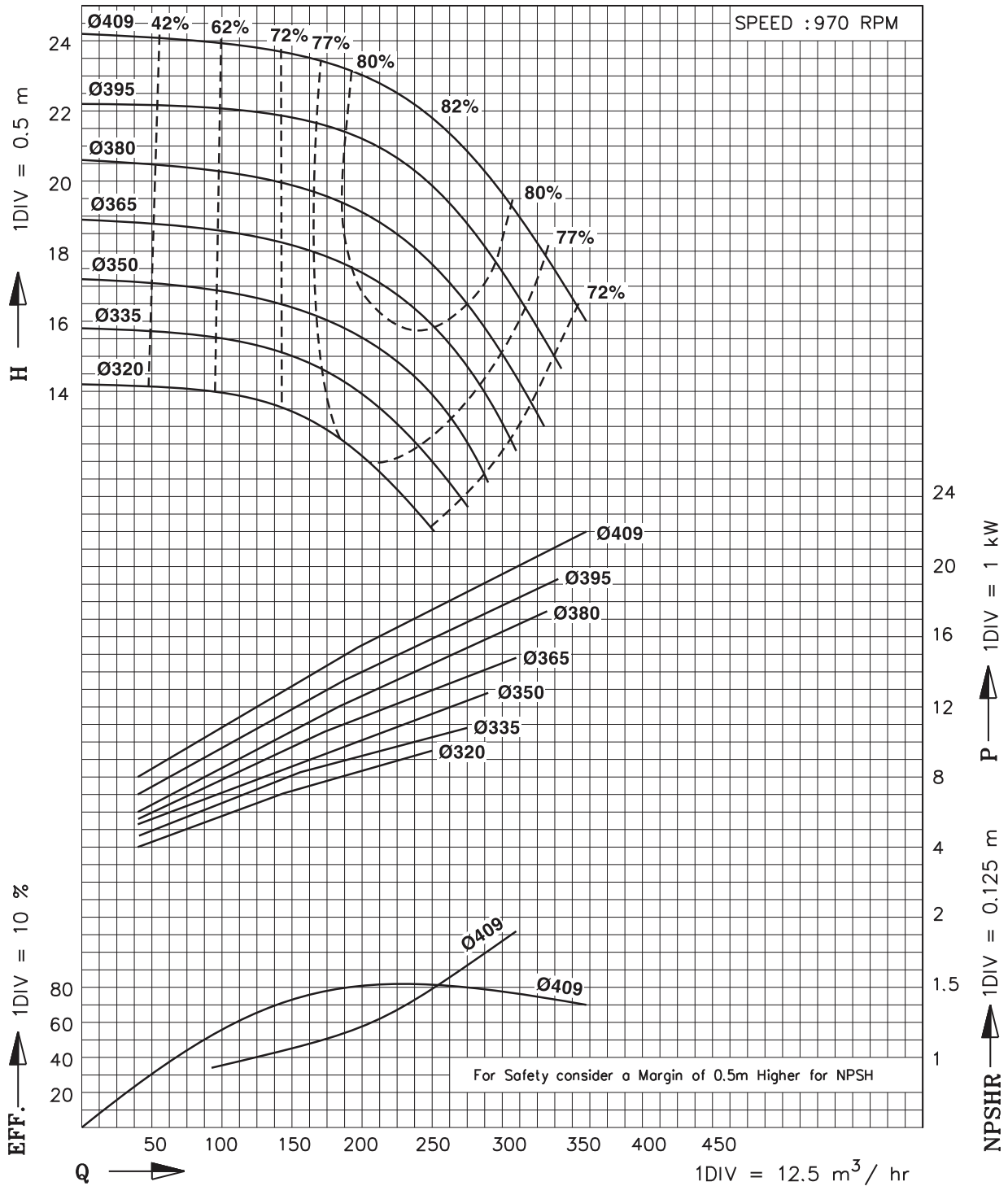



PERFORMANCE CURVE

Model : ECW-150/400

Note : Performance curve are as per specific gravity and viscosity of water.

SIZE : 200 x 150

