

Automatic Pressure Booster System

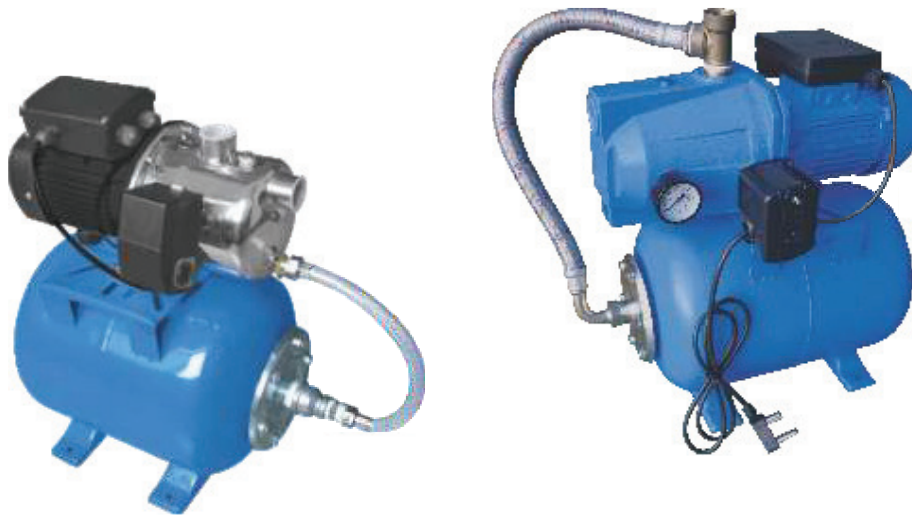

DESCRIPTION

C.R.I. Automatic pressure booster systems comprises of Self priming Jet pump (JTS / JTC - Series), Pressure tank, Mechanical Pressure switch & other accessories designed ingeniously for delivering optimal performance. This system eliminates the need of over-head tanks & float switch. The electro mechanical control device switches ON & OFF the pump automatically whenever the pressure reaches the minimum and maximum preset levels. It maintains uniform pressurized water in the pipelines suitable for all domestic applications.

FEATURES

- Sets free from operating the pump every time manually
- Eliminates need of overhead tank & float switch
- Ensures uninterrupted water supply with adequate pressure always
- Saves water, electricity & time
- Designed for easy installation

APPLICATION

For all pressure boosting applications in Houses, Multi-storeyed Apartments, Villas, Gardens, Commercial centers, Hotels, Restaurants, etc.,

DIMENSIONAL DETAILS

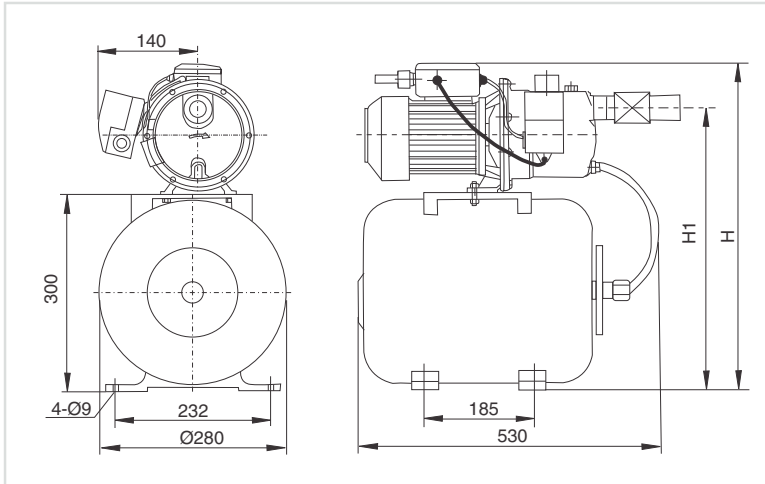

MODEL	Dimensions in mm		Weight in kg
	H	H1	
P24-JTS-3/05M	428	495	14.5
P24-JTS-3/07M	452	540	15.5

* All Dimensions are in mm.

PERFORMANCE DETAILS

Pressure Booster System with Stainless Steel Pumps

MODEL	TANK CAPACITY in ltrs	MOTOR POWER		Inlet & Outlet Size in Inches	Head (Suc) in m	l/s	0.42	0.61	0.66	Pressure switch setting (bar)		Pressure level in pressure tank (PSI)
		kW	HP				1.5	2.2	2.4	ON	OFF	
P24-JTS-3/05M	24	0.55	0.75	1 x 1	7	Head in metres	25	22	19	1	2.5	15 - 18
P24-JTS-3/07M	24	0.75	1.0	1 x 1	7		31	28	25	2.1	3.5	15 - 18

MODEL	TANK CAPACITY in ltrs	MOTOR POWER		Inlet & Outlet Size in Inches	Head (Suc) in m	l/s	0.42	0.61	0.66	Pressure switch setting (bar)		Pressure level in pressure tank (PSI)
		kW	HP				1.5	2.2	2.4	ON	OFF	
P24-JTB-3/05M	24	0.55	0.75	1 x 1	7	Head in metres	27	23	22	1.4	2.8	15 - 18
P24-JTB-3/07M	24	0.75	1.0	1 x 1	7		33	29	26	2.1	3.5	15 - 18

The above models can be supplied with 60 ltrs tank also.